

Alpha[®] EZ Thin Panel T-Cutter Manual



Part No: KEC-600
Version 1

TABLE OF CONTENTS

Introduction.....	3
About the Symbols.....	3
General Safety Instructions.....	3
EZ Thin Panel T-Cutter Schematic.....	4
Assembly Instructions.....	4
Replacement Parts.....	5
How to Operate.....	5
How to Replace the Guide Roller.....	7
Suggested Cutting Surface.....	7

INTRODUCTION

Thank you for purchasing the Alpha® EZ Thin Panel T-Cutter. Please read this instruction manual thoroughly to ensure safe and correct use of the EZ Thin Panel T-Cutter. Keep this manual in a place where operators can access it easily whenever necessary.

► ABOUT THE SYMBOLS

According to the hazard level, all safety notes in this manual are classified into “DANGER”, “WARNING”, and “CAUTION”.

 **DANGER!** Death or serious personal injury is imminent when handling this T-Cutter incorrectly.

 **WARNING!** There is a possibility of death or serious personal injury when handling this T-Cutter incorrectly.

 **CAUTION!** There is a possibility of personal injury or property damage when handling this T-Cutter incorrectly.

Note: In some situations, failing to observe **WARNING** notes could result in death or serious personal injury. Be sure to read and observe the safety notes to ensure safe and correct use of the T-cutter.

 **CAUTION!**

The following are important notes for products, operation, and maintenance applicable to this T-Cutter

► SAFETY INSTRUCTIONS

Read all these instructions before attempting to operate this product.

- Keep your work area clean and well lit. Cluttered benches and dark areas invite accidents.
- Use clamps or other practical way to secure and support the workpiece to a stable platform. Holding the work by hand or against your body is unstable and may lead to loss of control.
- Do not overreach. Keep proper footing and balance at all times. **Proper footing and balance enables better control of the tool in unexpected situations. Do not use on a ladder or unstable support.**
- Use safety equipment. Always wear eye protection. Dust mask, nonskid safety shoes, hard hat, or hearing protection must be used for appropriate conditions.

ALPHA® EZ THIN PANEL T-CUTTER

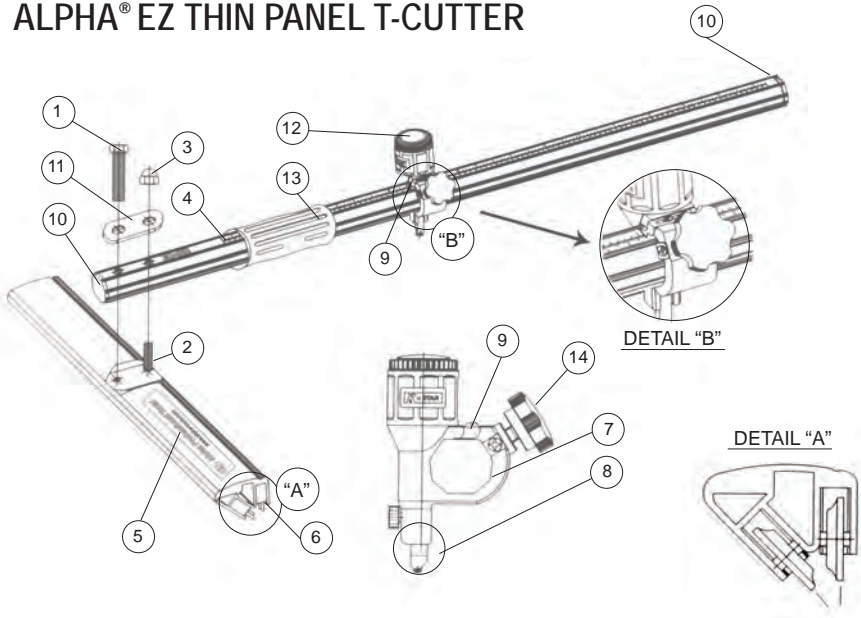

► ASSEMBLY INSTRUCTIONS

1. **Set the scaled bar (4) onto the pre-mounted bolt (2) of the roller housing (5).** Make sure that the rollers in the roller housing are in the correct position as the picture. (Detail "A")

**Tip: See page 7 for instructions on replacing the guide roller.*

2. **Fasten the bolt (1) and the cap nut (3).** The 2-hole washer (11) should be placed as the schematic indicates.

**Tip: Check if the scaled bar (4) is set 90 degrees to the roller housing (5)*

3. **Ensure that the rubber handle (13) has been mounted onto the scaled bar (4).** To adjust the position of the rubber handle (13), gently push at its edge towards the desired direction.

4. **Slide the cutting head holder (7) onto the scaled bar (4) then fasten the fixation screw (14).**

**Tip: Make sure the scale indicator (9) is facing toward the roller housing (5). The scale indicator (9) indicates the width of cut.*

REPLACEMENT PARTS

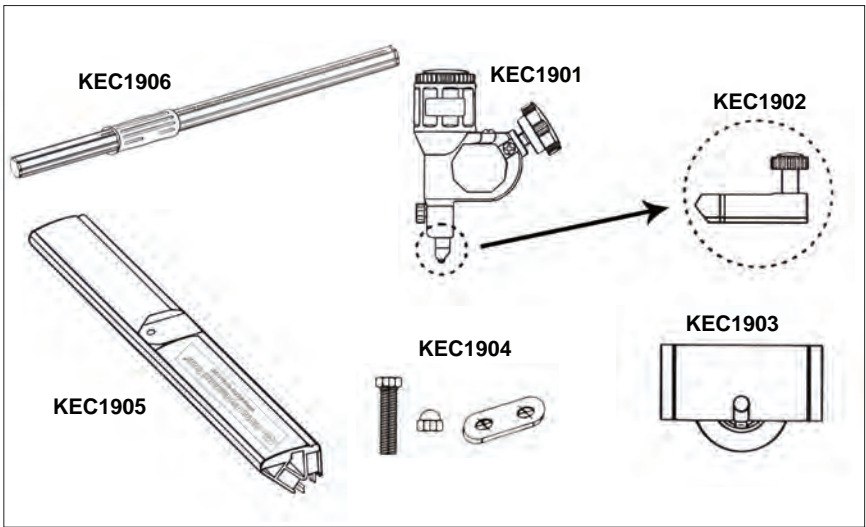

EZ Cutter Oil

PART NO.	DESCRIPTION
KEC1901	Cutting Head Holder
KEC1902	Cutting Head
KEC1903	Guide Roller (1 Pack= 20 Pieces)
KEC1904	Assembly Hardware
KEC1905	Roller Housing
KOC1000	EZ Cutter Oil

► HOW TO OPERATE

1. Remove the oil reservoir cap (12) and fill the reservoir (12) with Alpha® EZ Cutter Oil. (See Figure -1)



Figure-1

Note: Tighten reservoir cap after filling with oil.

2. Check if the red scale indicator (9) is facing towards the roller housing (5).
(See Figure 2)

Set the distance of score required by sliding the cutting head holder (7), the red indicator defines the width of score on the scale bar(4).

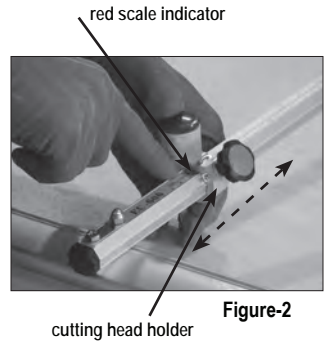

Figure-2

3. Place the roller of the roller housing (5) against the edge of the tile and put the cutting head (8) onto the tile to be cut. Grab the rubber handle (13) to have a safe and comfortable cut. (See Figure-3 and 4)

Note: (a) Loosen the reservoir cap before cutting.
(b) Make sure the EZ Cutter Oil comes out of the cutting head (8) prior to scoring.



Figure-3

4. Drag the EZ-cutter with slight pressure to the cutting direction. Make sure the edge of the tile is straight and clean for good cutting condition. (See Figure 4) After the material has been scored, tighten the reservoir cap.



Figure-4

***Tip:** If the cut tile dimension showed discrepancies, you could correct it with the indicator (9).

5. After the material has been scored, there are two options to snap the long thin panel.

METHOD ONE: Use the Alpha® EZ Glass Running Pliers (Part No. KOC412P). To use these running pliers, simply align the center indicator mark (RED) on the running pliers with the score mark on the thin panel and squeeze the handle (See Figure 5). The continuous even pressure provided by the Alpha® EZ Glass Running Pliers will make a clean break across the thin tile panel.



Figure-5

TIP: Teaming up and using two Alpha® EZ Glass Running Pliers at the same time with one on each side of the long panel is optional but recommended so the snapped panel does not get damaged.

6. **METHOD TWO:** Manually snap the material to complete the process. (See Figure-6)

TIP: Material that will be snapped will need to hang over the edge of the table prior to performing the "snap method". (See Figure 6)

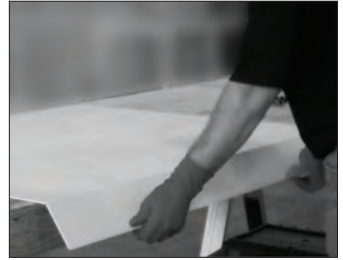

Figure-6

NOTE: If thin material has fiber glass on the back surface, you will need to use a razor blade to cut the fiber glass after the material has been scored and snapped. (See Figure 7)



Figure-7



CAUTION! Wear proper safety equipment due to the sharp edges.

7. When cutting is complete, the sharp edges become a safety hazard. You can easily smooth out the edges by using Alpha® Diamond Hand Pads (Electroplated #60 or #150 Grits). (See Figure-8)



Figure-8

***How to Replace the Guide Roller**

Guide rollers can be replaced by simply applying pressure with a screwdriver and popping them out as shown in the diagram to the right.

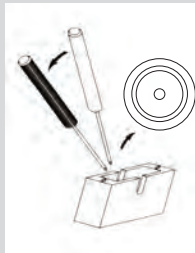

***Suggested Cutting Surface**

Alpha® recommends using a cutting surface similar to the one pictured below.

This table is simple to replicate using plywood and two saw horses.





103 Bauer Drive, Oakland, NJ 07436 • 800-648-7229 • Fax: 800-286-0114
www.alpha-tools.com

Copyright © 2014 Alpha Professional Tools. All rights reserved.

07/2014