

ALPHA

TOOLS FOR
**HARDSCAPE
CONTRACTORS**

PROVIDING BETTER
SOLUTIONS
TO THE
PROFESSIONAL



VERSION 5



WELCOME

Alpha Professional Tools® was founded in 1986 and has become a leading manufacturer of quality tools for professionals in the natural/engineered stone, porcelain, ceramic, glass, construction, marine and automotive industries. Alpha® provides the best products for cutting, drilling, shaping and polishing all types of materials.

In addition to providing the best products in the industry, Alpha Professional Tools® offers a variety of services to support their products.

Company Contact Information:

| | |
|---------------------------------|--------------------------------------|
| Headquarters & Training Center: | 103 Bauer Drive Oakland, NJ 07436 |
| Hours of Operation (EST): | 8:30 a.m. - 5:00 p.m. |
| Telephone No: | 201-337-3343 |
| Toll-Free No: | 800-648-7229 |
| Fax No: | 201-337-2216 |
| Customer Service Fax No: | 800-286-0114 |
| Tool Dept. Fax No: | 201-337-2265 |
| Accounting Dept. Fax No: | 201-337-2262 |

E-mail Orders to:
orderdesk@alpha-tools.com
tooldesk@alpha-tools.com

Contact Us:
www.alpha-tools.com
info@alpha-tools.com

Follow Us:



Sales Contacts by Territory – sales@alpha-tools.com

| | | | |
|----------------|--------------|-------------|--------------|
| Caribbean | 201-337-3343 | Northern CA | 925-428-1292 |
| Canada | 519-546-9861 | Northwest | 800-648-7229 |
| Central Plains | 800-648-7229 | NY Metro | 973-830-7681 |
| Florida | 786-570-4350 | Ohio Valley | 440-364-3759 |
| International | 201-337-3343 | Pacific | 800-648-7229 |
| Mid-Atlantic | 804-382-5357 | South | 713-252-9851 |
| Midwest | 630-849-7105 | Southeast | 678-977-1147 |
| Mountain | 480-848-6808 | Southern CA | 714-853-3476 |
| New England | 860-933-6626 | | |

TOOLS

GRINDERS

- PSG-658, High-Performance Pneumatic Grinder 6

STONE CUTTER

- PSC-600, High-Performance Pneumatic Stone Cutter 8
- ESC-125, Wet/Dry Stone Cutter 10
- Countertop Trim Kit 12
- ECC-125, Virtually Dust-Free Cutting Solution 13
- ECC-KIT, Dry Porcelain Paver Tile Cutting System 14

POLISHERS

- AIR-300 15
- AIR-830 / 850, High-Performance Pneumatic Polishers 16
- VDP-700, Variable Speed Rotary Polisher 18
 - Wool Pads 20
 - Rotary Backer Pads 20
- VSP-320, Variable Speed Wet Polisher 21

POLISHING KITS

- Paver Tile Bullnose Kit 22

CUTTING

DRY BLADES

- Plus 24
- Quad 24
- Eclipse II 25
- Eclipse Q 25
- Katana 26
- Ultracut GPM 26

WET BLADES

- Q-Cut 27
- Porcellana 28
- Porcellana PRS 28
- Vetro 29
- Vetro PRS 29

FLUSH CUTTING BLADES

- Vortex for Granite 30
- Vortex for Marble 30
- Ultracut APR 31

CURVE CUTTING BLADES

- Contour for Porcelain/Crystallized Glass 32
- Contour for Granite 33
- Contour for Marble 33

CHANNEL CUTTING BLADES

- Hot-Rod Blade 34

DEMOLITION SAW BLADES

- PT Cutter 35
- Blade Master 36
- Rescue Blade 36

BLADE ACCESSORIES

- Quad Adapters 37
- Flange Adapters 37
- Spike Ruler 37
- Dressing Stick 37

TABLE OF CONTENTS

PROFILING

PROFILERS

- Profiler B-Series..... 39
- Profiler Z-Series..... 39
- Profiler V-Series..... 40

DRILLING

CORE DRILL BITS

- Wet Core Bits..... 42
- Dry Core Bits..... 42

TRIMMER BITS

- Vacuum Brazed Trimmer Bit 43

DRILL BITS

- Electroplated Drill Bits..... 43

DRILL BIT ACCESSORIES

- Drill Bit Guide..... 44

POLISHING

DIAMOND PADS

- Diamond Hand Pads..... 46
- Ceramica EX..... 47
- Sandpaper 47

POLISHING WHEELS

- Antique Brush Wheels..... 48

ACCESSORIES

DUST-FREE GUARDS

- Ecoguard C..... 50
- Ecoguard D..... 50
- Ecoguard CD 51
- Ecoguard G / G7..... 51
- Ecoguard W5 / W6 / W9 52

BACKER PADS

- Rigid Backer Pads 53
- Flexible Backer Pads 53
- GV Backer Pads 53

MISCELLANEOUS

- Ground Fault Circuit Interrupter 54
- Safety Glasses..... 54
- Rust Inhibitor Oil 54
- Manifold System 55
- Hoses..... 56
- Wet Blade Cutting Kit..... 58
- Wet Polishing and Sanding Kit..... 59
- Pool Coping Kit..... 60
- Aprons..... 61
- G-Tape 63
- EZ Click System..... 66
- Stain Removers 66

TOOLS

High-performance tools,
designed for use in the
construction industry



PSG-658

HIGH-PERFORMANCE PNEUMATIC GRINDER

Newly developed motor
produces more power



Composite End Case to Prevent Freezing Hands



PSG-658

HIGH-PERFORMANCE
PNEUMATIC GRINDER

- Center Water-Feed System to Deliver Ample Water Regardless of Position
- 15ft. All-Weather Hoses with Flexibility Down To -40°F Or +140°F(-40°C To +60°C)
- Newly Developed Motor Produces More Power
- Lightweight and Ergonomically Designed for Better Maneuverability
- Composite End Case to Prevent Freezing Hands
- Silicon Gear Head Cover Provides Cushion and Keeps Hands Warm
- Enhanced Spindle Shaft for Easy Tool Removal (Wrench included)
- One Year Warranty (*See manual for details*)

| SPECIFICATION | DATA |
|-----------------------|-------------------|
| Model | PSG-658 |
| Air Pressure | 85 PSI (6 Bar) |
| Air Consumption | 15 CFM (425L/min) |
| Weight | 2.9 lbs (1.3 kgs) |
| No Load RPM | 8,500 RPM |
| Air Inlet | 1/4" BSPP |
| Water Inlet | 1/8" BSPP |
| Spindle | 5/8"-11 |
| Cutting Disc Diameter | 6" (150mm) |
| Length | 7-1/2" (190.5mm) |

| ITEM | QUANTITY |
|--|----------|
| Air Hose (15ft / 4.5m) | 1 |
| Water Hose (15ft / 4.5m) | 1 |
| Side Handle (reversible) | 1 |
| Rust Inhibitor Oil (6.7oz/200ml) | 1 |
| Screw (w/O-Ring Seal for Oil Port) | 1 |
| Exhaust Hose & Clamp | 1 |
| Spring Washer | 1 |
| 6" Safety Guard | 1 |
| Double End Wrench (19mm/22mm) | 1 |
| Phillips Screwdriver | 1 |
| Water Quick Coupler w/Shut-off Valve | 1 |
| O-Ring (O-Ring for Water Valve Repair) | 1 |
| Hex Wrench (6mm) | 1 |

| PART NO. | MAXIMUM RPMS | RECOMMENDED FOR | DESCRIPTION |
|----------|--------------|-----------------|--------------------------------|
| PSG-658 | 8,500 | Grinding | Pneumatic Grinder |
| AIR-008 | | Pneumatic Tools | Rust Inhibitor Oil 8oz (237ml) |

PSC-600

High-Performance Pneumatic Cutter/Grinder

*Winning Combinations
Without the Dust!*

Vexcel Rigid Disc



Spike Disc



VFlex Sanding Disc



CUTTER/GRINDER

PSC-600

HIGH-PERFORMANCE PNEUMATIC CUTTER



- Center Water-Feed System to Deliver Ample Water Regardless of Position
- 15ft. All-Weather Hoses with Flexibility Down To -40°F Or +140°F (-40°C To +60°C)
- Newly Developed Motor Produces More Power
- Lightweight and Ergonomically Designed for Better Maneuverability
- Composite End Case to Prevent Freezing Hands
- Silicon Gear Head Cover Provides Cushion and Keeps Hands Warm
- Enhanced Spindle Shaft for Easy Tool Removal (Wrench included)
- One Year Warranty (*See manual for details*)

| SPECIFICATION | DATA |
|-----------------------|-------------------|
| Model | PSC-600 |
| Air Pressure | 85 PSI (6 Bar) |
| Air Consumption | 15 CFM (425L/min) |
| Weight | 2.9 lbs (1.3 kgs) |
| No Load RPM | 8,500 RPM |
| Air Inlet | 1/4" BSPP |
| Water Inlet | 1/8" BSPP |
| Arbor | 7/8" (22mm) |
| Cutting Disc Diameter | 6" (150mm) |
| Length | 7-1/2" (190.5mm) |

| ITEM | QUANTITY |
|--|----------|
| Air Hose (15ft / 4.5m) | 1 |
| Water Hose (15ft / 4.5m) | 1 |
| Side Handle (reversible) | 1 |
| Rust Inhibitor Oil (6.7oz/200ml) | 1 |
| Screw (w/O-Ring Seal for Oil Port) | 1 |
| Exhaust Hose & Clamp | 1 |
| Spring Washer | 1 |
| 6" Safety Guard | 1 |
| Double End Wrench (19mm/22mm) | 1 |
| Phillips Screwdriver | 1 |
| Water Quick Coupler w/Shut-off Valve | 1 |
| O-Ring (O-Ring for Water Valve Repair) | 1 |
| Single Open End Wrench (22mm) | 1 |
| Hex Wrench (6mm) | 1 |
| Inner Flange for Cutting | 1 |
| Outer Flange | 1 |
| L-Bracket | 1 |
| Inner Flange for Grinding | 1 |



Center Water-Feed System to Deliver Ample Water Regardless of Position

| PART NO. | MAXIMUM RPMS | RECOMMENDED FOR | DESCRIPTION |
|----------|--------------|-----------------|--------------------------------|
| PSC-600 | 8,500 | Cutting | Pneumatic Stone Cutter |
| AIR-008 | | Pneumatic Tools | Rust Inhibitor Oil 8oz (237ml) |

STONE CUTTER

Introducing A New and Improved
Version of Our Popular **AWS-125...**

ALPHA[®]

ESC-125

WET/DRY STONE CUTTER

OSHA[®]
COMPATIBLE

DRY

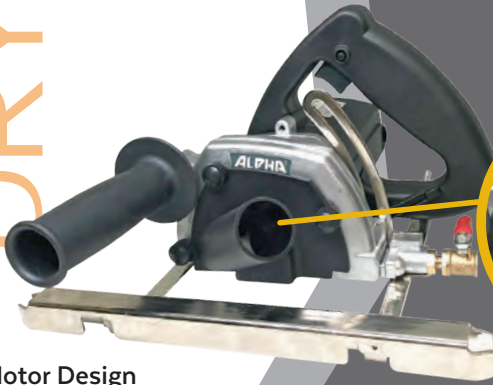

Dust Cover For HEPA
Vacuum Connection



- New Motor Design
- Kink Free Hybrid Water Supply Hose with Quick Change Connector

WET

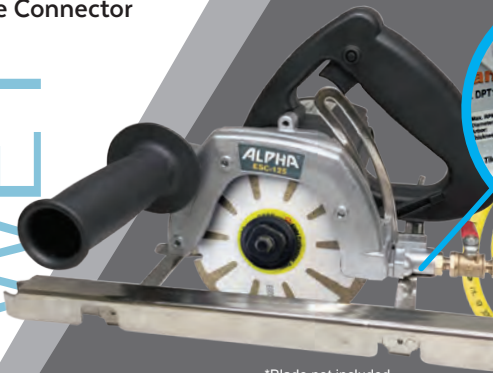

Newly Designed
Water Jet



*Blade not included

Quick Change
Connector

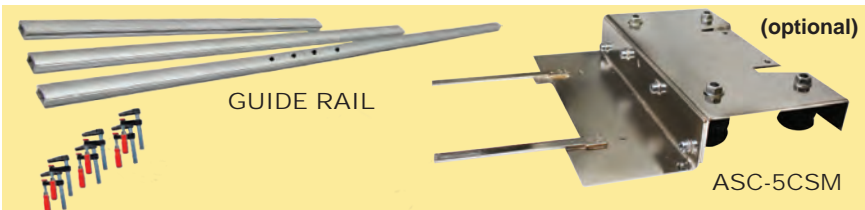

ESC-125

WET/DRY STONE CUTTER



- Precision Cuts Everytime
- Powerful Motor For Use On Porcelain Paver Tile, Granite, Quartz Surfaces, Marble, Limestone, Concrete and Sintered Slabs
- Water-Feed Supply Eliminates The Harmful Dust Particles
- Base Plate Allows Guides To Be Used in Multiple Ways
- Dust Cover for HEPA Vacuum Connection
- New Clamping System Ensures Cutting Stability
- Included Self-Stick Felt Strips Protects The Work Surface From Scratches
- Built-In GFCI (Ground Fault Circuit Interrupter)
- Great For Use With Curve Cutting Blades
- One Year Warranty (See manual for details)

| SPECIFICATION | DATA |
|-----------------------|-----------------------------|
| Model | ESC-125 |
| Rating | 110 Volts |
| Amperage | 11.2A |
| Power | 1200W |
| No Load Speed (min-1) | 12,000 RPM |
| Weight | 8.9 lbs (4.0 kgs) |
| Arbor | 7/8" (22.23mm) |
| Cutting Disc Diameter | 5" (125mm) |
| Plug Type | A (110V) |
| Cord | 15ft (4.5m) Single-Phase |
| Max. Cutting Depth | 1-5/8" (41mm) |

| ITEM | QUANTITY |
|----------------------------|----------|
| Dust Cover | 1 |
| Knob Bolt | 3 |
| TT Ruler Guide | 1 |
| Water Hose Assembly | 1 |
| Quick Connect Adapter | 1 |
| Side Handle | 1 |
| Screw (M6x30-Left) | 1 |
| Flange 3 | 1 |
| Carbon Brush Set | 1 |
| T-Handle Wrench | 1 |
| Open-End Wrench (22mm) | 1 |
| Self-stick Felt Strip Set | 1 |
| GFCI | 1 |
| EasyOn-EasyOff Sleeve | 1 |
| SS Flat Head Screw (M4x10) | 3 |
| Water Valve Assembly | 1 |

| PART NO. | SIZE | TYPE | ARBOR(S) | DESCRIPTION |
|----------|------|------|----------------|----------------------|
| ESC-125 | 5" | 110V | 7/8" (22.23mm) | Wet/Dry Stone Cutter |

COUNTERTOP TRIM KIT

COMPLETE TRIM KIT FOR A CUSTOM-LOOK



Part number: 5480-4150

COUNTERTOP TRIM KIT



Complete Trim Kit for a Custom Look

INCLUDES:

Wet/Dry Stone Cutter
ESC-125

5" Eclipse Blade
DEE005

5" Carriage Assembly for Stone Cutter
ASC-5CSM

4' Guide Rail with Clamps
ASC-GR04

- Recommended for Hard Surfaces
- Eclipse II Blade has 8mm Tall Diamond Layer for a Long Life
- Perfect for your Stone Tile Application
- High-End General Purpose Turbo Blade for Stone Fabricators
- Consistent Performance without Chipping
- Kit Contains: ESC-125 Stone Cutter, 5" Carriage Assembly, 5" Eclipse II Blade and 4' Guide Rail
- One Year Tool Warranty (*See manual for details*)

| PART NO. | DESCRIPTION |
|-----------|-------------------------------|
| 5480-4150 | Countertop Trim Kit (ESC-125) |

ECC-125

ECOCUTTER



- Virtually Dust-Free
- Portable Cutting System
- Accurate Cutting Performance
- Eliminates Downtime
- Built-in In-line circuit breaker
- Great for Grout Removal, Crack Chasing & Concrete Profiling
- One Year Warranty (See manual for details)

| SPECIFICATION | DATA |
|-----------------------|-------------------|
| Model | ECC-125 |
| Rating | 110 Volts |
| Amperage | 11.2A |
| Power | 1200W |
| No Load Speed (min-1) | 12,000 RPM |
| Weight | 9.5 lbs (4.3 kgs) |
| Arbor | 7/8" (22.23mm) |
| Cutting Diameter | 5" (125mm) |
| Maximum Cutting Depth | 1-1/8" (29mm) |

| ITEM | QUANTITY |
|----------------------|----------|
| Dust Hose | 1 |
| Dust Gate | 1 |
| Side Handle | 1 |
| Hexagon Ring Spanner | 1 |
| Wrench | 1 |
| Dust Bag | 1 |
| TT Ruler | 1 |
| Hook & Loop Strap | 2 |

| PART NO. | SIZE | TYPE | ARBOR(S) | DESCRIPTION |
|----------|---------------------|-------|----------------|---------------------------------------|
| ECC-125 | 5" | 110V | 7/8" (22.23mm) | Ecocutter |
| 133544 | 17" x 13-1/2" x 12" | | | Dust Bag w/strap |
| ECO-CARS | | Steel | | Dust Bag Carriage (includes Dust Bag) |

DUST BAG CARRIAGE



CUTTING KIT

ECC-KIT

DRY PORCELAIN PAVER TILE CUTTING SYSTEM

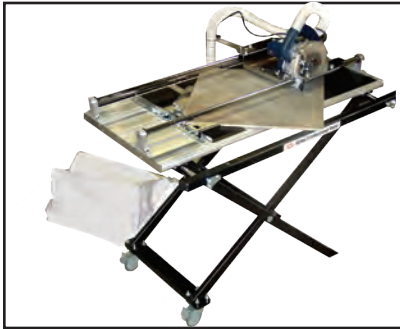

- Virtually Dust-Free
- Portable Cutting System
- Accurate Cutting Performance
- Eliminates Downtime and The Messy Cleanup
- Built-In Breaker Assembly
- Holds 3/4" Thick Porcelain Paver Tile
- One Year Tool Warranty (See manual for details)

| SPECIFICATION | DATA |
|-----------------------|--|
| Model | ECC-KIT (ECC-125) |
| Rating | 110 Volts |
| Amperage | 11.2 |
| Power | 1200W |
| No Load Speed (min-1) | 12,000 RPM |
| Weight | 9.5 lbs (4.3 kgs) |
| Arbor | 7/8" (22.23mm) |
| Cutting Diameter | 5"(125mm) |
| Maximum Cutting Depth | 1-1/8" (29mm) (without Ecocutter Table) |

| EQUIPMENT INCLUDED | QUANTITY |
|------------------------------|----------|
| ECC-125 | 1 |
| Dust Hose | 1 |
| Dust Gate | 1 |
| Side Handle | 1 |
| Hexagon Ring Spanner | 1 |
| Wrench | 1 |
| Dust Bag | 1 |
| TT Ruler Guide | 1 |
| Hook & Loop Strap | 2 |
| Ecocutter Table | 1 |
| Ecocutter Stand | 1 |
| Alpha® Ultracut GPM Blade 5" | 1 |
| Basic Instructional DVD | 1 |

| PART NO. | SIZE | TYPE | ARBOR(S) | DESCRIPTION |
|-----------|------------------|-----------|----------------|--------------------------|
| ECC-KIT | 5" | 110V | 7/8" (22.23mm) | Dry Cutting System |
| ECC-125 | 5" | 110V | 7/8" (22.23mm) | Ecocutter |
| 133544 | 17"x13-1/2 x 12" | | | Dust Bag w/strap |
| ECC-STAND | | | | Dry Cutting System Stand |
| ECC-TABLE | | | | Dry Cutting System Table |
| 170005 | | | | Ecocutter DVD |
| PART NO. | SIZE | THICKNESS | MAX RPM | ARBOR(S) |
| GPM0578 | 5" | 1.5mm | 12,200 | 7/8" |

AIR-300

MINI PNEUMATIC POLISHER



- High-Performance, Pneumatic Polishing Tool with A Central Water-Feed System
- No-Load 5,800 RPMs
- Lightweight and Ergonomically Design Reduces Fatigue
- Designed To Easily Maneuver in Small Areas Like Sink Rims and Bowls
- Consumes 10 CFM and Requires 87 PSI
- Only Requires 3HP Compressor
- One Year Warranty (See manual for details)

| SPECIFICATION | DATA |
|-----------------|-------------------------|
| Model | AIR-300 |
| Air Pressure | 87 PSI (0.6Mpa (6 bar)) |
| Air Consumption | 10 CFM (280L/Min) |
| No Load Speed | 5,800 RPM |
| Weight | 1.6 lbs / .731 kgs |
| Air Inlet | 1/4" BSPT |
| Water Inlet | 1/4" BSPP |
| Spindle | 5/8"-11 |



| ITEM | QUANTITY |
|---|----------|
| Air Hose 10ft (3m) | 1 |
| Water Hose 10ft (3m) | 1 |
| Faucet/Garden Hose Adapter | 1 |
| Wrench (17mm) | 1 |
| Rust Inhibitor Oil (1oz / 30cc) (Replace with: AIR-008) | 1 |



| PART NO. | MAXIMUM RPM | RECOMMENDED FOR | DESCRIPTION |
|----------|-------------|-----------------|--------------------------------|
| AIR-300 | 5,800 | Wet Polishing | Mini Pneumatic Polisher |
| AIR-008 | | Pneumatic Tools | Rust Inhibitor Oil 8oz (237ml) |

Ergonomic and lightweight for better maneuverability

AIR-830



FEATURES:

- *Newly Developed Motor Produces More Power*
- *Silicon Gear Head Cover Provides Cushion and Keeps Hands Warm*
- *New Splash Guard Allows for Better Visibility Without Being Splashed*
- *Enhanced Spindle Shaft for Easy Tool Removal (Wrench Included)*
- *One Year Warranty (See manual for details)*

AIR-850

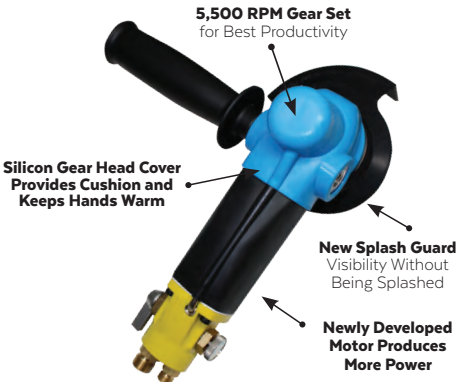

ITEMS INCLUDED:

| ITEM | QUANTITY |
|--|----------|
| Air Lead Hose 15ft. (4.5m) | 1 |
| Water Hose 15ft. (4.5m) | 1 |
| Side Handle (reversible) | 1 |
| Rust Inhibitor Oil (6.7oz / 200ml) | 1 |
| Screw (w/ O-Ring Seal for Oil Port) | 1 |
| Exhaust Hose with Clamp | 1 |
| Spring Washer | 1 |
| Splash Guard | 1 |
| Double End Wrench (19mm / 22mm) | 1 |
| Phillips Screwdriver | 1 |
| Water Quick Coupler w/ Shut-off Valve | 1 |
| O-Ring (O-Ring for Water Valve Repair) | 1 |

AIR-830 / AIR-834

HIGH-PERFORMANCE
PNEUMATIC POLISHER



AIR-830

4,000 RPM Gear Set
for Best Quality Results

| SPECIFICATION | DATA |
|-----------------|--------------------|
| Model | AIR-830/AIR-834 |
| Air Pressure | 85 PSI (6 Bar) |
| Air Consumption | 15 CFM (425L/min) |
| Weight | 2.75 lbs (1.2 kgs) |
| No load Speed | 4,000 RPM |
| Air Inlet | 1/4" BSPP |
| Water Inlet | 1/8" BSPP |
| Spindle | 5/8"-11 / M14-2 |

| PART NO. | MAXIMUM RPM | THREADS | RECOMMENDED FOR | DESCRIPTION |
|----------|-------------|---------|-------------------------------------|-----------------------------------|
| AIR-830 | 4,000 | 5/8"-11 | Wet Polishing, Drilling & Profiling | Pneumatic Polisher |
| AIR-834 | 4,000 | M14-2 | Wet Polishing, Drilling & Profiling | Pneumatic Polisher |
| AIR-008 | | | Pneumatic Tools | Rust Inhibitor Oil 8oz (237ml) |

AIR-850 / AIR-854

HIGH-PERFORMANCE
PNEUMATIC POLISHER



AIR-850

5,500 RPM Gear Set
for Best Productivity

| SPECIFICATION | DATA |
|-----------------|--------------------|
| Model | AIR-850/AIR-854 |
| Air Pressure | 85 PSI (6 Bar) |
| Air Consumption | 15 CFM (425L/min) |
| No load Speed | 5,500 RPM |
| Weight | 2.75 lbs (1.2 kgs) |
| Air Inlet | 1/4" BSPP |
| Water Inlet | 1/8" BSPP |
| Spindle | 5/8"-11 / M14-2 |

| PART NO. | MAXIMUM RPM | THREADS | RECOMMENDED FOR | DESCRIPTION |
|----------|-------------|---------|-------------------------------------|-----------------------------------|
| AIR-850 | 5,500 | 5/8"-11 | Wet Polishing, Drilling & Profiling | Pneumatic Polisher |
| AIR-854 | 5,500 | M14-2 | Wet Polishing, Drilling & Profiling | Pneumatic Polisher |
| AIR-008 | | | Pneumatic Tools | Rust Inhibitor Oil 8oz (237ml) |

VDP-700

VARIABLE SPEED ROTARY POLISHER



Spindle Lock



*Backer and Pad Not Included



VDP-700

WET/DRY VARIABLE SPEED ROTARY POLISHER



*Backer and Pad Not Included

- Variable Speed 700-3500 RPM with Soft Start
- Designed For The Polishing Professional
- Heavy-Duty Precision Gear System
- Powerful 11.0 Amp (rated) Motor
- Built-in Speed Stabilizer for Constant Speed Output
- Configured with A Long-life Motor and Carbon Brushes
- 25ft. 14 AWG Electrical Power Cord
- Lightweight for Better Manueverability
- Industrial Quality Polisher
- C-Handle & Side Handle for User Convenience
- One Year Warranty (*See manual for details*)

| SPECIFICATION | DATA |
|--------------------------|--------------------------------|
| Model | VDP-700 |
| Rating | 120 Volts |
| Amperage | 11.0A |
| Power | 1250W (Rated), 1900W (Maximum) |
| No Load Speed (Variable) | 700~3500 RPM w/Soft Start |
| Weight | 6.4 lbs (2.9 kgs) |
| Spindle | 5/8"-11 |
| Power Supply | Single-phase AC, 50/60Hz |
| Plug Type | A (120V) |
| Cord | 25ft (7.6m) (14 AWG) |
| Backing Plate Size | 7" (178mm) (Maximum) |
| Polishing Disc Size | 9" (228mm) (Maximum) |

| ITEM | QUANTITY |
|----------------------------|----------|
| Spanner Wrench | 1 |
| Hex Wrench | 1 |
| C-Handle w/Mounting Screws | 1 |
| Side Handle | 1 |
| Extra Carbon Brush Set | 1 |



*Backer and Pad Not Included

| PART NO. | SIZE | MAXIMUM RPM | TYPE | DESCRIPTION |
|----------|------|-------------|------|--------------------------------|
| VDP-700 | 7" | 700-3500 | 120V | Variable Speed Rotary Polisher |

WET SANDING/
POLISHING KIT

KIT Part # WSPKIT



(optional)

WOOL PADS

REMOVES DEEP SCRATCHES WITH EASE



- Premium Performance and Heat-Resistant
- Smoother Handling and Reduced Vibration
- For Use on Rotary Polishers

| PART NO. | SIZE | TYPE | RECOMMENDED FOR | MATERIAL | GRIT |
|----------|------|-------------|-----------------|-----------------------|------|
| WP003160 | 3" | Hook & Loop | Heavy Cutting | High-Nap Knitted Wool | T160 |
| WP006160 | 6" | Hook & Loop | Heavy Cutting | High-Nap Knitted Wool | T160 |
| WP007160 | 7" | Hook & Loop | Heavy Cutting | High-Nap Knitted Wool | T160 |

ROTARY BACKER PAD

FOR USE ON ROTARY POLISHERS



- Soft Molded Urethane With Flexible Edge
- Urethane Backing Makes for Greater Flexibility and Excellent Polishing
- Ideal for Contour Polishing
- For Use with Foam, Wool & Microfiber Pads
- Hook & Loop Allows for Fast Pad Changes
- Well Balanced for Smooth Polishing
- Absorbs Vibrations and Has Great Rebound Performance



Hook & Loop

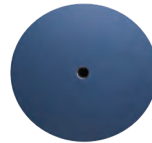

Adhesive

| PART NO. | SIZE | TYPE | RECOMMENDED FOR | THREADS |
|----------|------|-------------|------------------------------|---------|
| MP358HL | 3" | Hook & Loop | Foam, Wool & Microfiber Pads | 5/8"-11 |
| MP558HL | 5" | Hook & Loop | Foam, Wool & Microfiber Pads | 5/8"-11 |
| MP658HL | 6" | Hook & Loop | Foam, Wool & Microfiber Pads | 5/8"-11 |
| MP758HL | 7" | Hook & Loop | Foam, Wool & Microfiber Pads | 5/8"-11 |
| MP858HL | 8" | Hook & Loop | Foam, Wool & Microfiber Pads | 5/8"-11 |
| MP858GL | 8" | Adhesive | Foam, Wool & Microfiber Pads | 5/8"-11 |

VSP-320

VARIABLE SPEED
WET POLISHER



- Variable Speed 700-2500 RPM
- Heavy-Duty Gear System with Step-Down Transmission
- 15ft. Flexible All-Weather Water Hose
- 15ft. Electrical Power Cord Has An Inline GFCI
- EasyOn-EasyOff Sleeve Improves Maneuverability
- Adjustable Splash Guard
- Center Water-Feed System
- Ventilation Cap Diverts Water from Getting Into Motor Housing
- C-Handle & Side Handle for User Convenience
- One Year Warranty (See manual for details)

| SPECIFICATION | DATA |
|--------------------------|--------------------------|
| Model | VSP-320 |
| Rating | 120 Volts |
| Amperage | 7.0A |
| Power | 800W |
| No Load Speed (Variable) | 700~2500 RPM |
| Weight | 7.3 lbs (3.3 kgs) |
| Spindle | 5/8"-11 |
| Power Supply | Single-phase AC, 50/60Hz |
| Plug Type | A (120V) |
| Cord | 15ft (4.5m) |
| Polishing Disc Size | 4" (100mm) |

| PART NO. | TYPE | DESCRIPTION |
|----------|------|-----------------------------|
| VSP-320 | 120V | Variable Speed Wet Polisher |



| ITEM | QUANTITY |
|---------------------------------------|----------|
| Ground Fault Circuit Interrupter* | 1 |
| Flexible Hose w/ Garden Hose Adapter* | 1 |
| Wrench | 1 |
| C-Handle w/ Mounting Screws* | 1 |
| Side Handle (Reversible) | 1 |
| Extra Carbon Brush Set | 1 |
| Ventilation Cap w/ Rubber Band* | 1 |
| Splash Guard w/ Clamp | 1 |
| EasyOn-EasyOff Sleeve* | 1 |



*Factory Attached

PAVER TILE BULLNOSE KIT

CREATES A FACTORY FINISH ON-SITE



- Designed To Create A Bullnose Edge On Tile or Stone and Polish It To A Factory Quality Finish
- Goof-Proof Hand-Held Application
- Quality Finish Without The Factory
- Save Time and Money
- Has Everything You Need
- Kit Contains: VSP-320 Polisher, Profiler V, 4" Ceramica EX Polishing Discs, 4" Flexible Backer Pad and Apron
- One Year Tool Warranty (See manual for details)



PROFILING



POLISHING



KIT INCLUDES:
 VSP-320, PFV201, GP45/8PD, EX40200R,
 EX40500R, EX41000R, EX42000R, EX43000R
 and APRON2000

| PART NO. | DESCRIPTION |
|-----------|-----------------------------------|
| 5480-1230 | Paver Tile Bullnose Kit (VSP-320) |

CUTTING

Premium blades for all your cutting needs.



PLUS

ULTIMATE DRY BLADE FOR BLUE STONE



- Best Dry Cutting Turbo Blade on the Market
- Perfect for Blue Stone, Granite, and Other Hard to Cut Materials
- 8mm Tall Diamond Layer for a Long Life
- Recommended for Hard Concrete
- Chip-Free Cutting on Most Demanding Applications

| PART NO. | SIZE | THICKNESS | MAXIMUM RPM | ARBOR(S) |
|----------|--------|-----------|-------------|---------------|
| DA04A+ | 4" | 2.1mm | 14,500 | 20mm, 5/8" |
| DA05A+ | 4-1/2" | 2.1mm | 13,200 | 7/8", 20mm |
| DA05S | 5" | 2.1mm | 12,200 | 7/8" |
| DA06A+ | 6" | 2.1mm | 10,100 | 7/8", 5/8", ⚡ |
| DA07A+ | 7" | 2.3mm | 8,400 | 5/8", ⚡ |
| DA08A+ | 8" | 2.3mm | 7,400 | 5/8", ⚡ |
| DA09A+ | 9" | 2.3mm | 6,600 | 7/8", 5/8" |
| DA10A+ | 10" | 2.5mm | 5,900 | 1", 5/8" |
| DA11A+ | 10" | 2.5mm | 5,900 | 5/8" |
| DA12A+ | 12" | 2.5mm | 6,200 | 1", 20mm |
| DA13A+ | 12" | 2.5mm | 6,200 | 20mm |

QUAD

ULTIMATE DRY FLUSH CUTTING BLADE



- Requires Quad Drive to fit High-Speed Angle Grinder
- Fits most popular High-speed Angle Grinders
- Specially Designed for Flush Cutting
- Best Dry Cutting Turbo Blade on the Market
- Chip-Free Cutting on Most Demanding Applications



| PART NO. | SIZE | THICKNESS | MAXIMUM RPM | ARBOR(S) | THREADS |
|----------|------|------------------|-------------|--------------------------|---------|
| DA04AH | 4" | 2.1mm | 14,500 | 20mm Quad Drive | |
| DA05SH | 5" | 2.1mm | 12,200 | 20mm Quad Drive | |
| DA06AH | 6" | 2.1mm | 10,100 | 20mm Quad Drive | |
| DA07AH | 7" | 2.3mm | 8,400 | 20mm Quad Drive | |
| DA08AH | 8" | 2.3mm | 7,400 | 20mm Flange with 8 holes | |
| DA09AH | 9" | 2.5mm | 6,600 | 20mm Flange with 8 holes | |
| DA11AH | 10" | 2.5mm | 5,900 | 20mm Flange with 8 holes | |
| AAH-20 | | Aluminum Adapter | | 20mm | 5/8"-11 |
| BAH-5/8 | | Brass Adapter | | 20mm | 5/8"-11 |

ECLIPSE II

HIGH PERFORMANCE
DRY BLADE



- High-End General Purpose Turbo Blade for Stone Fabricators
- 8mm tall Diamond Layer for a Long Life
- Perfect for your Stone Tile Application
- Consistent Performance without Chipping
- Recommended for Hard Concrete

| PART NO. | SIZE | THICKNESS | MAXIMUM RPM | ARBOR(S) |
|----------|--------|-----------|-------------|---|
| DEE004 | 4" | 2.1mm | 14,500 | 20mm, 5/8" |
| DEE045 | 4-1/2" | 2.1mm | 13,200 | 7/8", 20mm |
| DEE005 | 5" | 2.1mm | 12,200 | 7/8" |
| DEE006 | 6" | 2.1mm | 10,100 | 7/8", 5/8", |
| DEE007 | 7" | 2.3mm | 8,400 | 5/8", |
| DEE008 | 8" | 2.3mm | 7,400 | 5/8", |

ECLIPSE Q

HIGH PERFORMANCE DRY
FLUSH CUTTING BLADE



- Requires Quad Drive or Flange Adapter to fit High-Speed Angle Grinder
- 8mm tall Diamond Layer for a Long Life
- Specially Designed for Flush Cutting
- High-End General Purpose Turbo Blade for Stone Fabricators
- Consistent Performance without Chipping



| PART NO. | SIZE | THICKNESS | MAXIMUM RPM | ARBOR(S) | THREADS |
|----------|------|------------------|-------------|--------------------------|---------|
| DEQ004 | 4" | 2.1mm | 14,500 | 20mm Quad Drive | |
| DEQ005 | 5" | 2.1mm | 12,200 | 20mm Quad Drive | |
| DEQ578 | 5" | 2.1mm | 12,200 | 7/8" Quad Drive | |
| DEQ006 | 6" | 2.1mm | 10,100 | 20mm Quad Drive | |
| DEQ678 | 6" | 2.1mm | 10,100 | 7/8" Quad Drive | |
| DEQ007 | 7" | 2.3mm | 8,400 | 20mm Quad Drive | |
| DEQ008 | 8" | 2.3mm | 7,400 | 20mm Flange with 8 holes | |
| AAH-7/8 | | Aluminum Adapter | | 7/8" | 5/8"-11 |
| AAH-20 | | Aluminum Adapter | | 20mm | 5/8"-11 |
| BAH-5/8 | | Brass Adapter | | 20mm | 5/8"-11 |

KATANA

ULTIMATE DRY BLADE FOR ALL TILES



- Tile Installer's Choice for Dry Cutting
- Specially Designed for 3/8" Hard Porcelain Tile
- Best Dry Cutting Tile Blade with Minimal Chipping
- Hybrid Dry Saw Blade for All Tiles
- Can Be used Wet or Dry

| PART NO. | SIZE | THICKNESS | MAXIMUM RPM | ARBOR(S) |
|----------|--------|-----------|-------------|---------------|
| DPT100 | 4" | 1.4mm | 14,500 | 20mm, 5/8" |
| DPT115 | 4-1/2" | 1.4mm | 13,200 | 7/8", 20mm |
| DPT125 | 5" | 1.4mm | 12,200 | 7/8" |
| DPT150 | 6" | 1.4mm | 10,100 | 7/8", 5/8", ◀ |

ULTRACUT GPM

VACUUM-BRAZED DIAMOND BLADE



- Perfect for 2cm Porcelain Paver Tile
- Cuts most materials without chipping or cracking
- Maintains excellent cutting performance at the maximum cutting depth
- Great for building contractors and fabricators who work with metal and composite materials
- Fits on most popular hand-held electric power tools

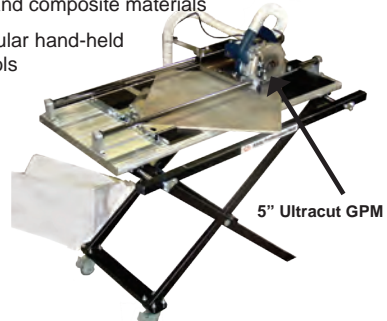

| PART NO. | SIZE | THICKNESS | MAXIMUM RPM | ARBOR(S) |
|----------|--------|-----------|-------------|---------------|
| GPM0420 | 4" | 1.5mm | 14,500 | 20mm, 5/8" |
| GPM4578 | 4-1/2" | 1.5mm | 13,200 | 7/8", 20mm |
| GPM0578 | 5" | 1.5mm | 12,200 | 7/8" |
| GPM06UN | 6" | 1.9mm | 10,100 | 7/8", 5/8", ◀ |
| GPM07UN | 7" | 1.9mm | 8,400 | 7/8", 5/8", ◀ |
| GPM08UN | 8" | 1.9mm | 7,400 | 7/8", 5/8", ◀ |
| GPM0978 | 9" | 2.2mm | 6,600 | 7/8", 5/8" |

Q-CUT

THE ULTIMATE WET BLADE FOR PORCELAIN PAVER TILE



- Formulated To Cut Hard Tiles Such As Quartzite/ Granite
- Tile Installer's Choice for Stone Tile
- Designed for Fast, Precision Chip-Free Cutting
- Perfect for 2cm Porcelain Paver Tile
- Wet Use Only (Except for 4-1/2" and 5" Blades Can Be Used Wet or Dry)



| PART NO. | SIZE | THICKNESS | MAXIMUM RPM | ARBOR(S) |
|----------|--------|-----------|-------------|---------------|
| QZ4578 | 4-1/2" | 1.6mm | 13,200 | 7/8", 20mm |
| QZ0578 | 5" | 1.6mm | 12,200 | 7/8" |
| QZ0658 | 6" | 1.4mm | 10,100 | 7/8", 5/8", ⌀ |
| QZ0758 | 7" | 1.6mm | 8,400 | 5/8" |
| QZ0858 | 8" | 1.6mm | 7,400 | 5/8" |
| QZ1058 | 10" | 2.0mm | 5,900 | 5/8" |

PORCELLANA

ULTIMATE WET BLADE FOR PORCELAIN TILES



- 3/8" (10mm) Tall Diamond Layer for Long Life
- Tile Installer's Choice for Chip Free Wet Cutting
- Recommended for Granite, Marble, Porcelain, Engineered Stone, Travertine and Ceramic Tiles
- Best Wet Cutting Tile Blade on the Market
- Hybrid Wet Saw Blade for All Tiles
- Wet Use Only

| PART NO. | SIZE | THICKNESS | MAXIMUM RPM | ARBOR(S) |
|----------|--------|-----------|-------------|------------|
| PT04A+ | 4-3/8" | 1.4mm | 13,200 | 7/8", 20mm |
| PT05S | 5" | 1.4mm | 12,200 | 7/8" |
| PT07A+ | 7" | 1.6mm | 8,400 | 5/8" |
| PT08A+ | 8" | 1.6mm | 7,400 | 5/8" |
| PT10A+ | 10" | 1.6mm | 5,900 | 5/8" |

PORCELLANA for PRS

ULTIMATE WET BLADE FOR PORTABLE RAIL SAWS



- 3/8" (10mm) Tall Diamond Layer for Long Life
- Tile Installer's Choice for Chip-Free Wet Cutting
- Recommended for Granite, Marble, Porcelain, Engineered Stone, Travertine and Ceramic Tiles
- Best Wet Cutting Tile Blade for Rail Saw on the Market
- Hybrid Wet Saw Blade for All Tiles
- Wet Use Only



| PART NO. | SIZE | THICKNESS | MAXIMUM RPM | ARBOR(S) |
|----------|------|-----------|-------------|----------------|
| PT0801 | 8" | 1.6mm | 7,400 | 1", 7/8", 5/8" |
| PT1001 | 10" | 1.6mm | 5,900 | 1", 5/8" |

VETRO

ULTIMATE WET BLADE FOR GLASS TILES



- Best Wet Cutting Glass Blade on the Market
- Designed for Chip-Free Cutting
- Tile Installer's Choice for Glass Tile
- Chip-Free Cutting on Most Demanding Applications
- Wet Use Only

| PART NO. | SIZE | THICKNESS | MAXIMUM RPM | ARBOR(S) |
|----------|--------|-----------|-------------|------------|
| WG0438 | 4-3/8" | 1.0mm | 13,200 | 7/8", 20mm |
| WG0700 | 7" | 1.6mm | 8,400 | 5/8" |
| WG0800 | 8" | 1.6mm | 7,400 | 5/8" |
| WG1000 | 10" | 1.6mm | 5,900 | 5/8" |

VETRO for PRS

VETRO FOR PORTABLE RAIL SAW



- Wet Use Only
- Designed for Chip-Free Cutting
- Tile Installer's Choice for Glass Tile
- Best Wet Cutting Glass Blade for Rail Saw on the Market
- Chip-Free Cutting on Most Demanding Applications

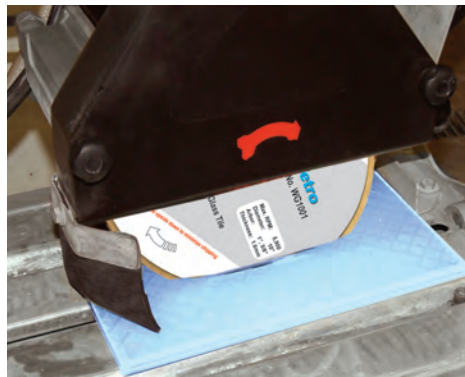

| PART NO. | SIZE | THICKNESS | MAXIMUM RPM | ARBOR(S) |
|----------|------|-----------|-------------|----------|
| WG1001 | 10" | 1.6mm | 5,900 | 1", 5/8" |

FLUSH CUTTING BLADE

VORTEX

INTRICATE & FLUSH CUTTING BLADE FOR GRANITE



- Requires Quad Drive to fit High-Speed Angle Grinder
- Perfect for Granite and Engineered Stone
- Specially Designed for Flush Cutting
- Stone Fabricator's Choice
- Chip-Free Cutting on Most Demanding Applications
- Side Protection Segments Help Cutting Straight



| PART NO. | SIZE | THICKNESS | MAXIMUM RPM | ARBOR(S) | THREADS |
|----------|------|------------------|-------------|-----------------|---------|
| FCD40AH | 4" | 2.5mm | 14,500 | 20mm Quad Drive | |
| FCD50AH | 5" | 2.5mm | 12,200 | 20mm Quad Drive | |
| AAH-20 | | Aluminum Adapter | | 20mm | 5/8"-11 |
| BAH-5/8 | | Brass Adapter | | 20mm | 5/8"-11 |

VORTEX

INTRICATE & FLUSH CUTTING BLADE FOR MARBLE



- Requires Quad Drive to fit High-Speed Angle Grinder
- Specially Designed for Marble and Lime Stone
- Specially Designed for Flush Cutting
- Stone Fabricator's Choice
- Chip-Free Cutting on Most Demanding Application

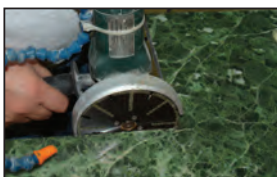

| PART NO. | SIZE | THICKNESS | MAXIMUM RPM | ARBOR(S) | THREADS |
|----------|------|------------------|-------------|-----------------|---------|
| FCM50AH | 5" | 1.6mm | 12,200 | 20mm Quad Drive | |
| AAH-20 | | Aluminum Adapter | | 20mm | 5/8"-11 |
| BAH-5/8 | | Brass Adapter | | 20mm | 5/8"-11 |

ULTRACUT APR SERIES

HYBRID BLADE FOR INTRICATE & FLUSH CUTTING



- Unique Design for Flush Cutting Applications
- Removes Anchor Bolts, Concrete Re-Bar and Pipe From Floors and Walls
- Great for Building Contractors and Fabricators Who Work with Metal and Composite Materials
- Accepts Alpha® Exclusive Quad Drive Adapter for Mounting On Angle Grinders for “Flush Cutting”
- Available in 4-1/2”, 5” and 7”



| PART NO. | SIZE | THICKNESS | MAXIMUM RPM | ARBOR(S) | THREADS |
|----------|--------|-----------|------------------|------------------|---------|
| APR45QA | 4-1/2" | 1.7mm | 13,200 | 20mm, Quad Drive | |
| APR05QA | 5" | 1.7mm | 12,200 | 20mm, Quad Drive | |
| APR07QA | 7" | 1.9mm | 8,400 | 20mm, Quad Drive | |
| BAH-5/8 | | | Brass Adapter | 20mm | 5/8"-11 |
| AAH-20 | | | Aluminum Adapter | 20mm | 5/8"-11 |



CONTOUR

CURVE CUTTING BLADE FOR PORCELAIN/CRYST. GLASS

CONTOUR FOR PORCELAIN

Curve Cutting on Porcelain, Crystallized Glass and Sintered Slabs



- Perfect for 2cm Porcelain Paver Tile
- Designed Specifically for Cutting Porcelain and Sintered Slabs
- Fits On Wet/Dry Stone Cutters
- Cuts Curved Areas Cleanly, Accurately and Safely While Allowing A Wider Kerf
- Direct Sintered Diamond Segments On Steel Core Prevents Undercutting
- Perfect to Cut Pool Skimmer Hole
- Can Be Used Either Wet or Dry

| PART NO. | SIZE | THICKNESS | MAXIMUM RPM | ARBOR(S) | DEPTH OF CUT |
|----------|--------|-----------|-------------|----------|--------------|
| CCP004 | 4" | 4.0mm | 14,500 | 7/8" | 3/4" |
| CCP045 | 4-1/2" | 4.0mm | 13,200 | 7/8" | 3/4" |
| CCP005 | 5" | 4.0mm | 12,200 | 7/8" | 1-1/4" |

CURVE CUTTING BLADE

CONTOUR

CURVE CUTTING BLADE FOR GRANITE AND ENG. STONE



- Specifically Developed for Cutting Granite Sinkholes
- Best Seller for Sinkhole Application
- Works Very Well On Engineered Stone, Quartzite and Harder Types of Natural Stone
- Cuts Curved Areas Cleanly, Accurately and Safely While Allowing A Wider Kerf
- Fits on Wet/Dry Stone Cutters
- Direct Sintered Diamond Segments On Steel Core Prevents Undercutting
- Fits On CNC Router with Cutting Head
- Can Be Used Either Wet or Dry

| PART NO. | SIZE | THICKNESS | MAXIMUM RPM | ARBOR(S) | DEPTH OF CUT |
|----------|--------|-----------|-------------|----------|--------------|
| CCB004 | 4" | 4.0mm | 14,500 | 7/8" | 3/4" |
| CCB045 | 4-1/2" | 4.0mm | 13,200 | 7/8" | 3/4" |
| CCB005 | 5" | 4.0mm | 12,200 | 7/8" | 1-1/4" |
| CCB006 | 6" | 4.0mm | 10,100 | 7/8" | 1-5/8" |

CONTOUR

CURVE CUTTING FOR MARBLE



- Design Specifically Developed for Cutting Marble and Limestone Sinkholes
- Fits On Wet/Dry Stone Cutters
- Cuts Curved Areas Cleanly, Accurately and Safely While Allowing A Wider Kerf
- Electroplated Diamonds on Both Sides of the Steel Core
- Can Be Used Either Wet or Dry

| PART NO. | SIZE | THICKNESS | MAXIMUM RPM | ARBOR(S) | DEPTH OF CUT |
|----------|------|-----------|-------------|----------|--------------|
| CCM005 | 5" | 1.4mm | 12,200 | 7/8" | 1-1/4" |

HOT-ROD

CHANNEL CUTTING BLADE FOR STAIR TREADS



- Perfect for Channel Cutting with Wet/Dry Stone Cutters
- Great for Grout Removal with EcoCutter
- Perfect to Cut Anti-Slip Grooves and Water Drip
- Reliable Proven Performer
- Can Be Used Wet or Dry

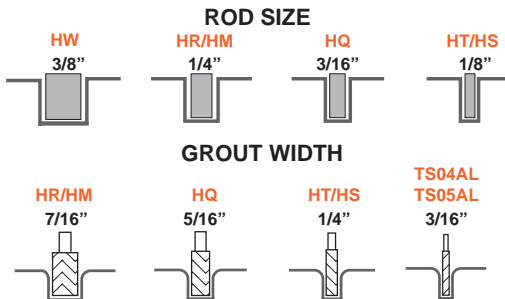
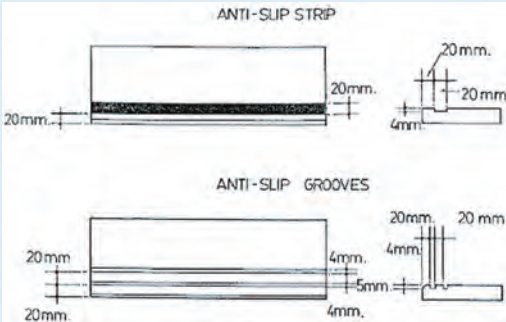

*Marble

| PART NO. | SIZE | THICKNESS | MAXIMUM RPM | ARBOR(S) | RECOMENDED FOR |
|----------|------|-----------|-------------|------------|-------------------|
| HT03A+ | 3" | 4.2mm | 14,500 | 7/8", 20mm | 1/8" Rod |
| HQ03A+ | 3" | 5.5mm | 14,500 | 7/8", 20mm | 3/16" Rod |
| HR03A+ | 3" | 7.0mm | 14,500 | 7/8", 20mm | 1/4" Rod |
| HW03A+ | 3" | 11.5mm | 14,500 | 7/8" | 3/8" Threaded Rod |
| HS03A* | 3" | 4.75mm | 14,500 | 7/8", 20mm | 1/8" Rod |
| HM03A* | 3" | 6.5mm | 14,500 | 7/8", 20mm | 1/4" Rod |
| HT04A+ | 4" | 4.2mm | 14,500 | 7/8", 20mm | 1/8" Rod |
| HR04A+ | 4" | 7.0mm | 14,500 | 7/8", 20mm | 1/4" Rod |

PT CUTTER

ULTIMATE DRY BLADE FOR PORCELAIN PAVER TILE



- Best Dry Cutting Turbo Blade on the Market
- Perfect for Porcelain Paver Tile
- 6mm Tall Diamond Layer for a Long Life
- Recommended for Landscaping Tiles
- Fits Most Gas-Powered Demolition Saws
- Can Be Used Wet or Dry
- Special Turbo Rim Diamond Layer Sintered Directly to the Steel Core
- Can Be Used On Portable Rail Saws



| PART NO. | SIZE | THICKNESS | MAXIMUM RPM | ARBOR(S) |
|----------|------|-----------|-------------|----------------|
| LT09A+ | 9" | 2.5mm | 6,600 | 7/8", 5/8" |
| LT12A+ | 12" | 2.6mm | 6,200 | 1", 7/8", 20mm |
| LT14A+ | 14" | 2.8mm | 5,360 | 1", 7/8", 20mm |

DEMOLITION BLADES

BLADEMASTER

HIGH-SPEED DIAMOND BLADE FOR PORCELAIN PAVER TILE



- High-Quality Laser-Welded Segmented Blades for High-Speed Demolition Saws
- Slices Through Materials with Ease
- Segment Height at 1/2" Ensure a Long Life
- Fits Masonry Saws & Road Cutters
- Can Be Used Wet or Dry
- Available in 12", 14" and 16" Diameters with Pin Hole

| PART NO. | SIZE | THICKNESS | MAXIMUM RPM | ARBOR(S) |
|----------|------|-----------|-------------|---------------|
| BML1214 | 12" | 2.9mm | 6,200 | 1" w/pin hole |
| BML1414 | 14" | 3.0mm | 5,360 | 1" w/pin hole |
| BML1614 | 16" | 3.1mm | 4,700 | 1" w/pin hole |

RESCUE

DEMOLITION BLADE CUTS IT ALL



- Slices Through Most Materials with Ease
- Works on Concrete, Paver, Stone, PVC Pipe, Ductile Iron, Granite, Tavertine, Blue Stone, Brick Block, Wood, Glass and Rubberized Materials
- Proven Winner for Firefighters, Police Officers and Construction Professionals
- Use on Gas-Powered Cut-Off Saw
- Available in 9", 12" and 14" Diameters

| PART NO. | SIZE | THICKNESS | MAXIMUM RPM | ARBOR(S) |
|----------|------|-----------|-------------|---------------------------|
| RB09A+ | 9" | 2.8mm | 8,300 | 7/8" |
| RB12A+ | 12" | 3.0mm | 6,200 | 1", 7/8", 20mm w/Pin Hole |
| RB14A+ | 14" | 3.2mm | 5,360 | 1", 7/8", 20mm w/Pin Hole |
| DR14A+ | 14" | 3.4mm | 5,360 | 1", 7/8", 20mm |



QUAD ADAPTERS



- Designed for Flush Cutting Blades with Four Mounting Holes
- Made Of Durable High-Quality Brass or Aluminum
- Easily Mounted To Any Quad Drive Blade
- Available in Various Thread Sizes

| PART NO. | TYPE | ARBOR(S) | THREADS |
|----------|----------|----------|------------|
| AAH-7/8 | Aluminum | 7/8" | 5/8"-11 |
| AAH-20 | Aluminum | 20mm | 5/8"-11 |
| BAH-5/8 | Brass | 20mm | 5/8"-11 |
| BAH-M10Q | Brass | 20mm | M10 - 1.25 |
| BAH-M14 | Brass | 20mm | M14-2 |

FLANGE ADAPTERS



- Designed for Blades That Are Eight Inches or Larger with Eight Mounting Holes
- Made Of Durable High-Quality Steel
- Easily Mounted To Any Large Flush Cutting Blade
- Available in 5/8"-11 and M14-2 Thread Sizes

| PART NO. | TYPE | THREADS |
|----------|---------|---------|
| FAH-5/8 | Adapter | 5/8"-11 |
| FAH-M14 | Adapter | M14-2 |

SPIKE RULER



- Designed As A Precision Ruler That Will Not Move On Thin Porcelain Tiles or Panels with Texturized Surfaces
- Secures Ruler To The Material
- Convenient and Easy To Use
- Made Of Aluminum with A Wood Base

| PART NO. | SIZE |
|----------|-----------|
| SPR100 | 3'4" (1m) |

DRESSING STICK



- Designed To Expose New Cutting Surfaces or Re-Open Glazed Diamond Blades and Grinding Wheels
- Removes Sinter Bond From Cutting Edge
- Can Be Used To Ease Sharp Corners
- Bond Type: Silicon Carbide

| PART NO. | SIZE | GRIT |
|----------|------------------|------|
| 290006 | 8" x 1.5" x 1.5" | 60 |

PROFILING

Perfect round over edges



Demi-Bullnose



Full Bullnose



Straight Edge

PROFILER B-SERIES

CREATES PERFECT
DEMI-BULLNOSE EDGE



- Perfect for 2cm Porcelain Paver Tile
- Use On Travertine, Granite, Engineered Stone, Marble, Concrete, Crystallized Glass and Porcelain Slabs
- Create A Perfect Demi-Bullnose/Roundover Edge Treatment
- Nylon Guide and Rotary Touchier Assures The Proper Depth Of Cut Is Achieved
- Equipped with A 5/8"-11 Female Thread and Internal Water Passage Holes
- Fits On All Popular Water-Fed Polishers

| PART NO. | SIZE | MAXIMUM RPM | THREADS | SHAPE |
|----------|-----------------------------|-------------|-------------|---------------|
| PFB051 | 3/16" (0.5cm) | 3,500 | 5/8"-11 | Demi-Bullnose |
| PFB101 | 3/8" (1.0cm) | 3,500 | 5/8"-11 | Demi-Bullnose |
| PFB131 | 1/2" (1.3cm) | 3,500 | 5/8"-11 | Demi-Bullnose |
| PFB201 | 3/4" (2.0cm) | 3,500 | 5/8"-11 | Demi-Bullnose |
| PFBNG01 | Fits up to 4cm Profilers | | Nylon Guide | |
| PFBNG02 | Fits All Sizes of Profilers | | Nylon Guide | |

PROFILER Z-SERIES

PERFECT 90-DEGREE
EDGE GRINDING



- Perfect for 2cm Porcelain Paver Tile
- Vertical Grinding On All Types Of Materials
- Never Loses Shape for True Zero Tolerance
- Nylon Guide and Rotary Touchier Assures Uniformity
- Equipped with A 5/8"-11 Female Thread and Internal Water Passage Holes
- Fits On All Popular Water-Fed Polishers

| PART NO. | SIZE | MAXIMUM RPM | THREADS |
|----------|-----------------------------|-------------|-------------|
| PFZ301 | 1-1/4" (3cm) | 3,500 | 5/8"-11 |
| PFZ401 | 1-1/2" (4cm) | 3,500 | 5/8"-11 |
| PFBNG01 | Fits up to 4cm Profilers | | Nylon Guide |
| PFBNG02 | Fits All Sizes of Profilers | | Nylon Guide |

PROFILER V-SERIES

CREATES PERFECT BULLNOSE EDGE



- Perfect for 2cm Porcelain Paver Tile, Pool Coping, Steps and Caps
- Create A Perfect Bullnose/Roundover Edge Treatment
- Use On Travertine, Granite, Engineered Stone, Marble, Limestone, Concrete, Crystallized Glass and Porcelain Slabs
- Eliminate The Time-Consuming Calibration Process for Seamed Pieces
- Nylon Guide and Rotary Touchier Assures The Edges Are Uniform
- Equipped with A 5/8"-11 Female Thread and Internal Water Passage Holes
- Fits On All Popular Water-Fed Polishers

| PART NO. | SIZE | MAXIMUM RPM | THREADS |
|----------|--------------------------|-------------|-------------|
| PFV201 | 3/4" (2cm) | 3,500 | 5/8"-11 |
| PFV301 | 1-1/4" (3cm) | 3,500 | 5/8"-11 |
| PFV401 | 1-1/2" (4cm) | 3,500 | 5/8"-11 |
| PFV501 | 2" (5cm) | 5,000 | 5/8"-11 |
| PFV601 | 2-3/8" (6cm) | 5,000 | 5/8"-11 |
| PFBNG01 | Fits up to 4cm Profilers | | Nylon Guide |
| PFBNG02 | Fits all Profilers | | Nylon Guide |



PROFILER B



PROFILER V



PROFILER Z

DRILLING

Versatile and can be adapted for use in construction trades wherever holes are needed.



WET CORE BITS

ULTIMATE WET CORE DRILLING BIT



- Perfect for Porcelain Paver Tile
- Designed for Drilling The Faucet-Mounting Holes in Countertops and Vanities
- Very Fast Cutting On Granite and Engineered Stone
- Make Clean Rounded Corners for Square or Rectangular Sinkholes
- Versatile and Adaptable in Many Industries for Water, Gas and Electrical Piping
- Fits On Most Popular Water-Fed Polishers

| PART NO. | DIAMETER | MAXIMUM RPM | THREADS |
|----------|----------|-------------|---------|
| DCB00380 | 3/8" | 3,500 | 5/8"-11 |
| DCB00500 | 1/2" | 3,500 | 5/8"-11 |
| DCB00750 | 3/4" | 3,500 | 5/8"-11 |
| DCB01000 | 1" | 3,500 | 5/8"-11 |
| DCB01250 | 1-1/4" | 3,500 | 5/8"-11 |
| DCB01375 | 1-3/8" | 3,500 | 5/8"-11 |
| DCB01500 | 1-1/2" | 3,500 | 5/8"-11 |
| DCB02000 | 2" | 3,500 | 5/8"-11 |
| DCB02500 | 2-1/2" | 3,500 | 5/8"-11 |

DRY CORE BITS

HIGH-SPEED DRY CORE BIT FOR GRANITE/ENG. STONE



- Perfect for Porcelain Paver Tile
- Designed for Jobsite Drilling Of Faucet-Mounting Holes in Countertops and Vanities
- Very Fast Cutting On Granite and Engineered Stone
- Convenient Dry Application
- Make Clean Rounded Corners for Square or Rectangular Sinkholes
- Versatile and Adaptable in Many Industries for Water, Gas and Electrical Piping
- Fits On Most Popular High-Speed Grinders

| PART NO. | DIAMETER | MAXIMUM RPM | THREADS |
|----------|----------|-------------|---------|
| DRB00500 | 1/2" | 12,000 | 5/8"-11 |
| DRB00750 | 3/4" | 12,000 | 5/8"-11 |
| DRB01000 | 1" | 12,000 | 5/8"-11 |
| DRB01250 | 1-1/4" | 12,000 | 5/8"-11 |
| DRB01375 | 1-3/8" | 12,000 | 5/8"-11 |
| DRB01500 | 1-1/2" | 12,000 | 5/8"-11 |
| DRB02000 | 2" | 12,000 | 5/8"-11 |

VACUUM BRAZED TRIMMER BIT

DRY CUTTING OF LARGE HOLES OR CURVED LINES



- Great For Use In Construction Trades Wherever Non-Standard Shaped Cutouts As Needed
- Perfect For Electrical Receptacles, Water-Valve Holes, Drains, Shower Knobs, Etc.
- Vacuum Brazed Technology Provides Extended Life
- Use On Granites, Engineered And Natural Stones, Porcelain And Ceramic Tiles
- Can Be Used Wet Or Dry
- Fits On A High-Speed Trimmer Tools

| PART NO. | DIAMETER | MAXIMUM RPM |
|----------|----------|-------------|
| DTB00250 | 1/4" | 33,000 |

ELECTROPLATED DRILL BITS

PREMIUM DRILL BITS FOR ANCHOR/PIPE HOLES



- Designed for Drilling Holes in Tile and Stone for Pre-Installation or Post-Installation Placement
- Works Great On Marble, Granite, Engineered Stone, Ceramic, Porcelain and Glass Tile and Panels
- Can Be Used On A Standard 3/8" or Larger Drill
- Can Fit On Water-Fed Polishers with 5/8"-11 Spindles Using The Drill Bit Adapter
- Ideal for Drilling Holes for Anchors for Bathroom Fixtures, Faucet and Plumbing Pipes
- Available in 3/16", 1/4", 5/16", 3/8", 1/2", 1-3/8" and 1-1/2" Sizes
- Wet Use Only

| PART NO. | DIAMETER | MAXIMUM RPM | TYPE |
|----------|----------|-------------|----------------------|
| CH7205 | 3/16" | 3,500 | 3/8" Shank |
| CH7206 | 1/4" | 3,500 | 3/8" Shank |
| CH7208 | 5/16" | 3,500 | 3/8" Shank |
| CH7210 | 3/8" | 3,500 | 3/8" Shank |
| CH7212 | 1/2" | 3,500 | 3/8" Shank |
| CH7235 | 1-3/8" | 3,500 | 3/8" Shank |
| CH7240 | 1-1/2" | 3,500 | 3/8" Shank |
| CH1058 | | | Adapter 10mm to 5/8" |

*(for all polishers)

DRILL BIT GUIDE

WATER DELIVERY SYSTEM



- Prevents Wandering Drill Bits
- Delivers Sufficient Water While Providing A Secure Drilling Position
- Fits Up To 1-3/8" Diameter
- Use It with Electroplated Drill Bits
- Ideal When Drilling 1/4" Anchor Holes When Installing Towel Bars, Soap Dishes, Shelves, Cabinets and Shower Door Frames
- Suction Cup Creates A Vacuum That Secures The Guide During Application

HOW TO USE:



Soak the foam rubber on the back side with water.



Press the body to the tile and make sure it adheres properly.



Pour water up to the mark on the tank.



Slide the switch to the open position. Make sure the water drips.



Place tip of drill bit into the guide position. Then start drilling.



Slide switch to the closed position. Pull the rubber to remove the water-feed system.



NOTE: working with mosaic tile or near grout lines use tape to secure.*

| PART NO. | DESCRIPTION |
|----------|---------------------------------------|
| WDS138 | Drill Bit Guide/Water Delivery System |

POLISHING

Full range of Superior Wet and Dry Diamond polishing pads



HAND PADS

HAND POLISHING PADS

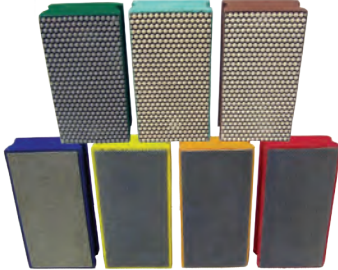

- Convenient, On-Site Polishing
- Use On Travertine, Porcelain Paver Tile, Glass, Ceramics, Marble, Granite, Concrete, Terrazzo and Quartz Surfaces
- Two Bond Types To Provide The Best Possible Finish
- Available in Electroplated and Resin Grits

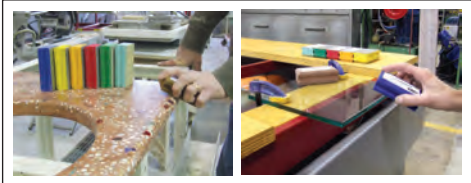

ELECTROPLATED GRITS:

This type of pad uses nickel plating technology to hold each individual diamond in place and is available in 60, 150, 300 and 500 grits.



RESIN GRITS:

This type has a finer diamond grit than electroplated pads. The resin bond is coated on a special backing material and is available in 1000, 2000 and 3000 grits best suited for honing to polishing.

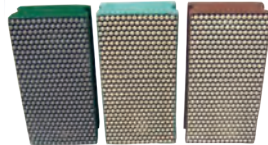

| PART NO. | GRIT | COLOR | BOND TYPE |
|----------|------|-------------|---------------|
| DHP0060 | 60 | Blue | Electroplated |
| DHP0150 | 150 | Yellow | Electroplated |
| DHP0300 | 300 | Orange | Electroplated |
| DHP0500 | 500 | Red | Electroplated |
| DHP1000 | 1000 | Dark Green | Resin |
| DHP2000 | 2000 | Light Green | Resin |
| DHP3000 | 3000 | Brown | Resin |
| DHPKIT | | | Set of 7 |

CERAMICA EX

WET POLISHING FOR ALL STONES

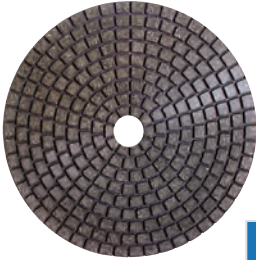

- Produces A High-Quality Shine
- Polishes On Porcelain, Granite, Travertine, Limestone, Concrete, etc.
- Ideal for Polishing Inside Corners and A Tight Radius
- Works Very Well On Tough Materials Including Tough To Polish Black and Green Marbles
- Extremely Flexible

| HOOK AND LOOP | | 3" | 4" | 5" |
|---------------|---------------------|----------|----------|----------|
| GRIT | COLOR | PART NO. | PART NO. | PART NO. |
| 200 | Yellow | EX30200R | EX40200R | EX50200R |
| 500 | Red | EX30500R | EX40500R | EX50500R |
| 1000 | Dark Green | EX31000R | EX41000R | EX51000R |
| 2000 | Light Green | EX32000R | EX42000R | EX52000R |
| 3000 | Brown | EX33000R | EX43000R | EX53000R |
| ALL | Assortment (1 each) | | EX40KIT | |

SANDPAPER

CONCRETE AND MARBLE POLISHING



- Waterproof Hook and Loop Backed Silicon Carbide Abrasive
- Use On Marbles and Softer Types of Natural Stone
- Can Also Be Used To Polish Glass, Metal and Wood
- Very Adaptable To Onsite Work and Easy To Use
- Resists Clogging When Used Wet
- Can Be Used Wet or Dry

| HOOK AND LOOP | | 4" | 5" |
|---------------|----------|----------|----------|
| GRIT | QUANTITY | PART NO. | PART NO. |
| 80 | 50 | MP40080 | MP50080 |
| 120 | 50 | MP40120 | MP50120 |
| 240 | 50 | MP40240 | MP50240 |
| 320 | 50 | MP40320 | MP50320 |
| 400 | 50 | MP40400 | MP50400 |
| 500 | 50 | MP40500 | MP50500 |
| 600 | 50 | MP40600 | MP50600 |
| Assortment | 50 | MP40KIT | MP50KIT |

ANTIQUÉ BRUSH WHEELS

BRUSH WHEELS FOR TEXTURED FINISHES



- Create A Textured Finish On The Edge and Surface Of Engineered Stone/Quartz Surfaces
- Developed with TYNEX®, A Filament From Dupont, To Ensure Safety and Exceptional Performance
- Utilizes A Snail Lock Adapter (SFAT)
- Fits Most Popular Edge Polishing Machines, Hand-Held Sanders and Polishers
- Grits Sequence of #24, #36, #60, #120, #240 and #320
- Can Be Used On Other Stone Such As Granite



| SNAIL LOCK | | | 4" | 5" |
|--------------------|-----------|-------------|----------|----------|
| GRIT | BOND TYPE | MAXIMUM RPM | PART NO. | PART NO. |
| 24 | Resin | 4,000 | AB4024 | AB5024 |
| 36 | Resin | 4,000 | AB4036 | AB5036 |
| 60 | Resin | 4,000 | AB4060 | AB5060 |
| 120 | Resin | 4,000 | AB4120 | AB5120 |
| 240 | Resin | 4,000 | AB4240 | AB5240 |
| 320 | Resin | 4,000 | AB4320 | AB5320 |
| Snail Lock Adapter | | 4,000 | PVA-5/8 | |
| Snail Lock Adapter | | 2,000 | | SFAT-5/8 |

ACCESSORIES

Exclusively from Alpha® for the most popular tools



ECOGUARD C HYBRID DUST COLLECTION COVER FOR CUTTING



- Designed for Collecting Dust When Using A High-Speed Angle Grinder
- Accepts Up To 5" Diameter Blades
- Can Be Used with or Without A Vacuum
- Rugged Construction for Heavy-Duty Applications
- Removes More Than 90% Of Dust
- Fits On Selected 4-1/2"- 5" High-Speed Angle Grinders
- Straight Precise Cuts Using Foot Plate
- Adjustable Cutting Depth

| PART NO. | SIZE | DESCRIPTION |
|----------|------|---|
| ECOGRDCT | 5" | Dust Collection Cover C |
| 201549 | | Dust Bag |
| 500026 | 18" | Flexible Connector Hose (1-1/2" Tapered-2-1/4") |
| 500073 | 54" | Flexible Connector Hose (1-1/2" Tapered-2-1/4") |

ECOGUARD D DUST AND DEBRIS GUARDS FOR DRILLS / HAMMER DRILLS



- Collects Dust & Debris with Ease While Using Drills/ Hammer Drills
- Convenient and Easy to Use
- Eliminates Clean-Up and Downtime on the Jobsite
- Fits Most Popular Drills and Hammer Drills
- Made for: Makita® BHR202Z, Bosch RHH180, DeWalt DCH253, Milwaukee 2605-20, Hilti TE4-A18



Optional Universal Handle



Optional Vacuum Adapter Kit



Optional Exhaust Hose

| PART NO. | SIZE | RECOMMENDED FOR | DESCRIPTION |
|----------|------------|---------------------|---|
| ECOGRDDL | ≥ 6" | Long Drill Bits | Dust Collection Cover DL |
| ECOGRDDS | ≤ 6" | Short Drill Bits | Dust Collection Cover DS |
| 803172 | | Ecoguard D | Universal Handle for Hammer Drills |
| ECOVAKIT | | Use With Ecoguard D | Vacuum Adapter Kit |
| VH91100 | 12ft /3.6m | 3/4" Hose Diameter | Exhaust Hose 1-1/4" O.D. threaded x 2-1/4" standard |

ECOGUARD CD

DUST AND WATER GUARD FOR CORE DRILLING



- Wet/Dry Cover for Drilling and Core Drilling Applications
- Fits Most Vacuum Dust Hoses
- Accepts up to 2-1/2" Core Bit
- Can Be Secured On Horizontal and Vertical Surfaces with Vacuum During Application
- Prevents Splashing When Used with Water

| PART NO. | RECOMMENDED FOR | DESCRIPTION |
|----------|-----------------|--------------------------|
| ECOGRDCD | Core Drilling | Dust Collection Cover CD |

ECOGUARD G5 / G7

DUST COLLECTION COVER FOR GRINDING



- Designed for Collecting Dust When Using A High-Speed Angle Grinder
- Accepts Grinding Wheels Up To: 5" (G5), 7" (G7)
- Rugged Construction for Heavy-Duty Applications
- Perfect for Grinding and Sanding or Surface Preparation Work
- Can Grind Tight Against The Wall
- Clear Cover for Better Visibility
- Fits On Most High-Speed Angle Grinders: 4-1/2"- 5" (G5), 7" & 9" (G7)
- Easy Installation and Wheel Changes
- The G7 Has A Flexible Head Allowing for A Natural Grinding Motion
- Removes More Than 90% of the Dust
- Must Be Used with A Vacuum

| PART NO. | SIZE | DESCRIPTION |
|----------|------|---|
| ECOGRDGR | 5" | Dust Collection Cover G5 |
| ECOGRDG7 | 7" | Dust Collection Cover G7 |
| 500026 | 18" | Flexible Connector Hose (1-1/2" Tapered-2-1/4") |
| 500073 | 54" | Flexible Connector Hose (1-1/2" Tapered-2-1/4") |
| ECOG5KIT | 5" | Ecoguard G5 & 18" Connector Hose Kit |
| ECOG7KIT | 7" | Ecoguard G7 & 54" Connector Hose Kit |

ECOGUARD G7



PART# ECOGRDG7

ECOGUARD W5 / W6 / W9

DUST COLLECTION COVER FOR WIDER KERF CUTTING



PART#: ECOGRDW6



PART#: ECOGRDW5

- Designed for Collecting Dust and Debris When Using A High-Speed Angle Grinder
- Perfect for Tuckpointing and Crack Chasing
- Accepts 5" Diameter Blades (W5), 6" Diameter Blades (W6), 7" and 9" Diameter Blades (W9)
- Removes More Than 90% Of Dust
- Rugged Construction for Heavy-Duty Applications
- Straight Precise Cuts Using Support Base
- Easy Installation and Blade Changes
- Fits On Selected 4-1/2", 5", 6", 7" and 9" High-Speed Angle Grinders
- Adjustable Cutting Depth - Maximum 1-1/2" (W5), 1-3/4" (W6) and 2-3/8" (W9)
- Must Be Used with A Vacuum



PART#: ECOGRDW9



| PART NO. | SIZE | DESCRIPTION |
|----------|------|---|
| ECOGRDW5 | 5" | Dust Collection Cover W5 |
| ECOGRDW6 | 6" | Dust Collection Cover W6 |
| ECOGRDW9 | 9" | Dust Collection Cover W9 |
| 500026 | 18" | Flexible Connector Hose (1-1/2" Tapered-2-1/4") |
| 500073 | 54" | Flexible Connector Hose (1-1/2" Tapered-2-1/4") |
| ECOW5KIT | 5" | Ecoguard W5 & 18" Connector Hose Kit |
| ECOW6KIT | 6" | Ecoguard W6 & 18" Connector Hose Kit |
| ECOW9KIT | 9" | Ecoguard W9 & 54" Connector Hose Kit |

RIGID BACKER PADS

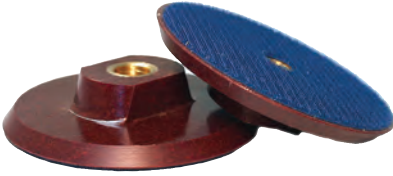

- High-Quality Backer Pad Is Super Rigid and Flat
- Eliminates The Wavy Finish When Polishing
- Hook and Loop Backed
- The Rigidness Of The Pad Enables Work in Small Areas Such As Corners or Staircases
- Accepts Polishing Pads, Sandpaper and Felt Wheels

| PART NO. | SIZE | MAX RPM | THREADS |
|----------|------|---------|---------|
| GP35/8RG | 3" | 6,000 | 5/8"-11 |
| GP45/8RG | 4" | 6,000 | 5/8"-11 |
| GP55/8RG | 5" | 6,000 | 5/8"-11 |
| RGSPACER | | | Spacer |

FLEXIBLE BACKER PADS

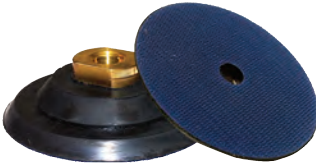

- High-Quality Backer Pad Is Extremely Flexible
- Ideal for Tough Contours and Inside Curves
- Hook and Loop Backed
- Highly Resistant To The Rigors Of Daily Use Provides A Long Life
- Accepts Polishing Pads, Sandpaper and Felt Wheels

| PART NO. | SIZE | MAX RPM | THREADS |
|----------|------|---------|---------|
| GP25/8PD | 2" | 6,000 | 5/8"-11 |
| GP35/8PD | 3" | 6,000 | 5/8"-11 |
| GP45/8PD | 4" | 6,000 | 5/8"-11 |
| GP55/8PD | 5" | 6,000 | 5/8"-11 |

GV BACKER PADS



- High-Quality Backer Pad Is Rigid and Flat, But Provides Just The Right Amount Of Flexibility
- Ideal for Bullnosed Edges and Flat Surfaces.
- Hook and Loop Backed
- Accepts Polishing Pads, Sandpaper and Felt Wheels
- Fits On Makita® GV5000 & GV5010 Sanders

| PART NO. | SIZE | MAXIMUM RPM | DESCRIPTION |
|----------|------|-------------|--------------|
| GV4MPPD | 4" | 4,500 | M8-1.25 Male |
| GV5MPPD | 5" | 4,500 | M8-1.25 Male |

ACCESSORIES

GROUND FAULT CIRCUIT INTERRUPTER



- Protect Polishing Personnel From Lethal Ground Current Loads
- Highly Recommended Piece Of Equipment
- Rated for 15 Amps

| PART NO. | DESCRIPTION |
|----------|----------------------------------|
| GFCI-1 | Ground Fault Circuit Interrupter |

SAFETY GLASSES



- Designed for Safety and Comfort
- A Lightweight Frame with Padded Temples
- Adjustable Side Arms
- Soft Rubber Nose Bridge
- Clear Anti-Scratch Lenses
- Available in a single pair or 12-pack
- Complies with standard # BS EN 166:2001



| PART NO. | DESCRIPTION |
|----------|------------------------------|
| 173002 | Safety Glasses (Box of 12) |
| 173008 | Safety Glasses (Single Pair) |

RUST INHIBITOR OIL



- Protects Your System From Rust
- Keeps Pneumatic Tools Lubricated

| PART NO. | RECOMMENDED FOR | DESCRIPTION |
|----------|-----------------|-----------------------------------|
| AIR-008 | Pneumatic Tools | Rust Inhibitor Oil 8oz (237ml) |

Filter/Regulator MANIFOLD SYSTEM

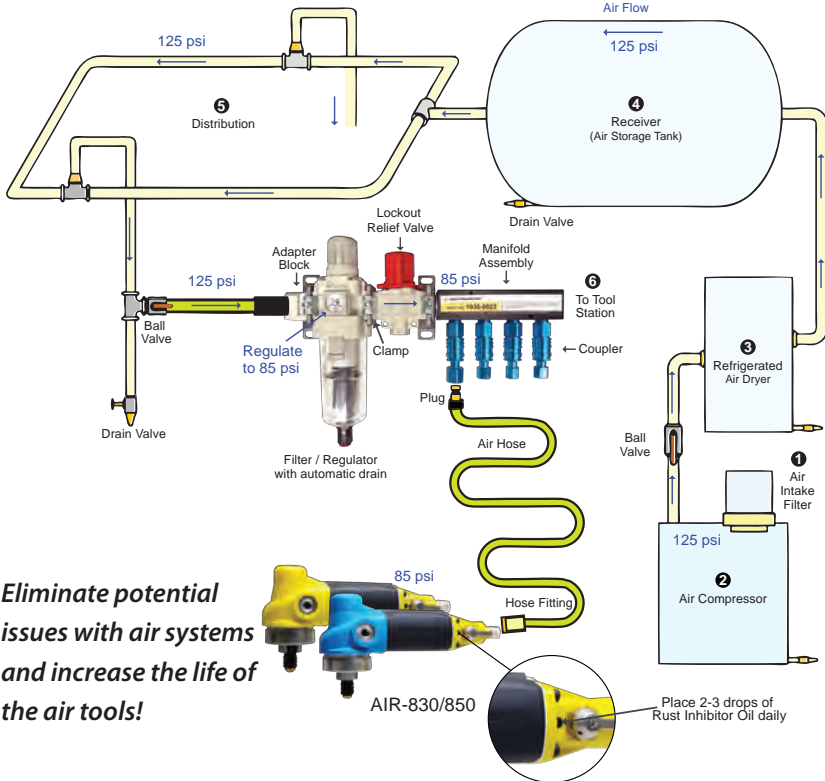

Eliminate potential issues with air systems and increase the life of the air tools!

Can be easily CUSTOMIZED to your shop requirements!

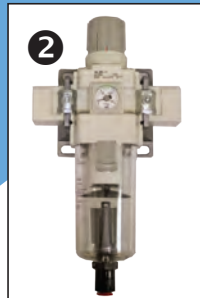
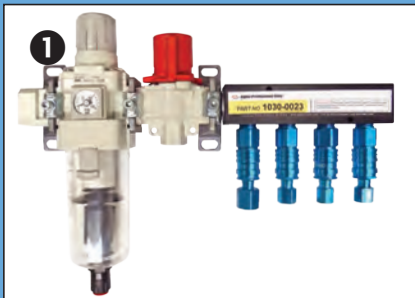

1 Complete System for Multiple Tools

| PART NO. | CFM | DESCRIPTION | ADAPTER BLOCK | PORT | PLUGS INCLUDED |
|-----------|-----|--------------------------------|---------------|------------|--|
| 1030-0021 | 53 | 3/8" Filter/Regulator Manifold | 3/8" NPT | 3 Couplers | (3) 1/4" Female NPT |
| 1030-0022 | 53 | 3/8" Filter/Regulator Manifold | 1/2" NPT | 3 Couplers | (3) 1/4" Female NPT |
| 1030-0023 | 106 | 1/2" Filter/Regulator Manifold | 1/2" NPT | 4 Couplers | (3) 1/4" Female NPT + (1) 3/8" Female NPT |
| 1030-0024 | 106 | 1/2" Filter/Regulator Manifold | 3/4" NPT | 4 Couplers | (3) 1/4" Female NPT + (1) 3/8" Female NPT |

2 Filter Regulator Kits for a Single Tool

| PART NO. | SIZE | TYPE | DESCRIPTION |
|-----------|---------|---------------------------|---|
| 1030-0070 | 53 CFM | 3/8" Filter/Regulator Kit | Filter/Regulator, Adapter Blocks & T-Clamps |
| 1030-0071 | 53 CFM | 3/8" Filter/Regulator Kit | Filter/Regulator, Adapter Blocks & T-Clamps |
| 1030-0072 | 53 CFM | 3/8" Filter/Regulator Kit | Filter/Regulator, Adapter Blocks & T-Clamps |
| 1030-0073 | 106 CFM | 1/2" Filter/Regulator Kit | Filter/Regulator, Adapter Blocks & T-Clamps |
| 1030-0074 | 106 CFM | 1/2" Filter/Regulator Kit | Filter/Regulator, Adapter Blocks & T-Clamps |
| 1030-0075 | 106 CFM | 1/2" Filter/Regulator Kit | Filter/Regulator, Adapter Blocks & T-Clamps |

HOSES

- All-Weather Flexibility From -40°F to +200°F
- Kink-Free Under Pressure
- Lightweight and Abrasion Resistant
- Zero Memory Allowing It To Lay Flat
- Made Of A Premium Hybrid Polymer Material
- Comes in Many Lengths
- Pneumatic and Water Hoses Available
- Many Connectors Available



AIR HOSE

(FOR AIR-680/830/850/PSC-600/PSG-658)

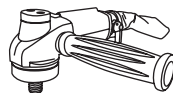

| PART NO. | SIZE | DIAMETER | THREADS |
|-----------|------------|----------|-------------------------------------|
| 1030-0002 | 15ft./4.5m | 1/4" | 1/4" NPSM x 1/4" NPT(Female Swivel) |
| 1030-0010 | 20ft./6.0m | 1/4" | 1/4" NPSM x 1/4" NPT(Female Swivel) |

Available Hose sizes: 25ft, 30ft, 35ft & 40ft. Call for Custom sizes or for more information.



WATER HOSE

(FOR AIR-680/830/850/PSC-600/PSG-658)

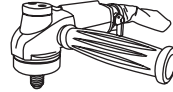

| PART NO. | SIZE | DIAMETER | THREADS |
|-----------|------------|----------|-----------------------------|
| 1030-0003 | 15ft./4.5m | 1/4" | 1/8" NPSM x 3/4" 11GHT(GHT) |
| 1030-0011 | 20ft./6.0m | 1/4" | 1/8" NPSM x 3/4" 11GHT(GHT) |

Available Hose sizes: 25ft, 30ft, 35ft & 40ft. Call for Custom sizes or for more information.



ADAPTER HOSE (FOR MANIFOLD SYSTEMS)

| PART NO. | SIZE | DIAMETER | THREADS |
|-----------|-----------|----------|-----------------|
| 1030-0025 | 1ft./0.3m | 1/2" | 1/2" NPT Swivel |
| 1030-0026 | 2ft./0.6m | 1/2" | 1/2" NPT Swivel |
| 1030-0027 | 3ft./0.9m | 1/2" | 1/2" NPT Swivel |



MOBILE HOSE (FOR MANIFOLD SYSTEMS)

| PART NO. | SIZE | DIAMETER | THREADS |
|-----------|------------|----------|----------------------------------|
| 1030-0050 | 15ft./4.5m | 1/2" | 1/2" NPT Swivel w/Hose Protector |
| 1030-0052 | 20ft./6.0m | 1/2" | 1/2" NPT Swivel w/Hose Protector |

Available Hose sizes: 25ft, 30ft, 35ft & 40ft....Custom sizes also available. Call for more information.



EXHAUST HOSE (SPECIALTY)

- Use with ECOVAKIT

| PART NO. | SIZE | DIAMETER | THREADS |
|----------|------------|----------|--|
| VH91100 | 12ft./3.6m | 3/4" | 1-1/4" O.D. threaded x 2-1/4" standard |

WET BLADE
CUTTING KIT

CONVERT A HIGH-SPEED ANGLE
GRINDER INTO A WET TOOL



WBC9KIT



CUTTING

- Can Be Used On Most Grinders With Minimal Alterations
- Fits Most 7" and 9" Angle Grinders
- Includes Kink-Free, Water-Feed Supplies, Plus GFCI



PROFILING



GRINDING

Kit includes: 9" Safety Guard, Loc-Line Assembly, Plastic Tie, 4 Plastic Collars, Adapter (1/4 NPT>>>M10*P.1.0), Water Hose Assembly, Memory Wrap (3ft. / 1M), Quick Connect Adapter, GFCI Plug (120V), Hook & Loop Tie & Screw w/Spring Lock Washer

| PART NO. | SIZE | TYPE | RECOMMENDED FOR | DESCRIPTION |
|-----------|------|------|-----------------------------------|-----------------------|
| WBC9KIT | 9" | 110V | 7" & 9" High-Speed Angle Grinders | Wet Blade Cutting Kit |
| WBC9KIT2V | 9" | 220V | 7" & 9" High-Speed Angle Grinders | Wet Blade Cutting Kit |

WET BLADE CUTTING KITS

CONVERT DRY GRINDER FOR WET CUTTING



- Designed To Convert A High-Speed Angle Grinder Into A Wet Tool
- Can Be Used On Most Grinders with Minimal Alterations
- Fits Most 4-1/2", 5" and 6" High-Speed Angle Grinders
- Kink-Free Water Hose for Easy Maneuverability and Reducing Operator Fatigue
- Save Money and Use Your Tool Wet or Dry!

Kit includes: Safety Guard, Loc-Line Assembly, Plastic Tie, Stainless Steel Collar, Plastic Collar, Adapter (1/4 NPT>>>M10*P.1.O), Water Hose Assembly, Memory Wrap (3ft. / 1M), Quick Connect Adapter, GFCI Plug (120V) & Hook & Loop Tie

| PART NO. | SIZE | TYPE | RECOMMENDED FOR | DESCRIPTION |
|-----------|------|------|---|-----------------------|
| WBC5KIT | 5" | 110V | 4-1/2", 5" & 6" High-Speed Angle Grinders | Wet Blade Cutting Kit |
| WBC6KIT | 6" | 110V | 4-1/2", 5" & 6" High-Speed Angle Grinders | Wet Blade Cutting Kit |
| WBC5KIT2V | 5" | 220V | 4-1/2", 5" & 6" High-Speed Angle Grinders | Wet Blade Cutting Kit |
| WBC6KIT2V | 6" | 220V | 4-1/2", 5" & 6" High-Speed Angle Grinders | Wet Blade Cutting Kit |

WET SANDING/
POLISHING KIT

CONVERTS DRY POLISHER / SANDER INTO A WET TOOL



- Designed To Convert A Dry Polisher Into A Wet Tool
- Save Money and Use Your Tool Wet or Dry!
- Quick Solution for OSHA Compliance
- Kit includes: Safety Guard, Loc-Line Assembly, Water Hose Assembly, Memory Wrap (3ft. / 1M), Quick Connect Adapter, GFCI Plug (120V) & Hook & Loop Strap

Kit includes: Safety Guard, Loc-Line Assembly, Water Hose Assembly, Memory Wrap (3ft. / 1M), Quick Connect Adapter, GFCI Plug (120V) & Hook & Loop Strap

| PART NO. | RECOMMENDED FOR | DESCRIPTION |
|----------|---------------------|-----------------------------|
| WSPKIT | Sanders & Polishers | Wet Sanding & Polishing Kit |

POOL COPING KIT

PROFILING



SANDING



KIT INCLUDES

VDP-700 VARIABLE SPEED ROTARY POLISHER
Professional Grade Industrial Polisher
Part #: **VDP-700**

WET SANDING/POLISHING KIT
Designed to convert a Variable Grinder, Sander or Polisher into a Wet Sanding/Polishing Tool
Part #: **WSPKIT**

PROFILER V
Creates A Perfect Bullnose/Roundover Edge Treatment
Part #: **PFV501**

FLEXIBLE BACKER PAD 5"
High-Quality Backer Pad Is Extremely Flexible
Part #: **GP55/8PD**

SANDPAPER #80 GRIT
Multi-Purpose Sanding of Marble & Softer Types of Natural Stone
Part #: **MP50080**

MULTI-PURPOSE WATERPROOF APRON SLEEVELESS
Part #: **APRON2000**

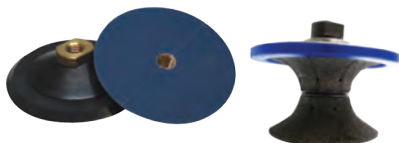

KIT Part # 5480-6100

| PART NO. | RECOMMENDED FOR | DESCRIPTION |
|-----------|-----------------|-----------------|
| 5480-6100 | Pool Coping | Pool Coping Kit |



Multi-Purpose Waterproof Apron - LONG SLEEVE



Customizable Cuff
with Easy
Cut Lines for a
Perfect Fit

Wet / Dry Use



APRON

MULTI-PURPOSE
APRON



- Rubber Cuffs Provides Full Coverage
- Bright Neon Yellow Color Provides Greater Visibility
- Perfect for Wet or Dry Environments
- Protects From Dust, Water and Other Chemicals
- Dual-Adjustable Clips Makes For A Perfect Fit



| PART NO. | SIZE | TYPE | DESCRIPTION |
|-----------|-------------|-------------|--|
| APRON2LSR | 55"L X 60"W | Long Sleeve | Multi-Purpose Waterproof Apron (Regular) |
| APRON2LSS | 42"L X 41"W | Long Sleeve | Multi-Purpose Waterproof Apron (Small) |

APRON

MULTI-PURPOSE
APRON SLEEVELESS



- Sleeveless with Wide Straps for Ease and Comfort
- Bright Neon Yellow Color Provides Greater Visibility
- Perfect for Wet or Dry Environments
- Protects From Dust, Water and Other Chemicals
- Dual-Adjustable Clips Makes For A Perfect Fit



| PART NO. | SIZE | TYPE | DESCRIPTION |
|-----------|-------------|------------|--|
| APRON2000 | 55"L X 60"W | Sleeveless | Multi-Purpose Waterproof Apron (One Size Fits All) |

G-TAPE

ALL PURPOSE
PROTECTION & REPAIR TAPE

Nichigo G-Tape

 INNOVATIVE
SOLUTIONS

LDPE film _____

HDPE cloth _____

LDPE film _____

Acrylic PSA layer _____



All G-Tape™ products feature a patented combination of solvent acrylic adhesive with an advanced backing substrate that results in unmatched performance.

MULTI-PURPOSE APPLICATIONS

Multi-Purpose Tape

Multi-Purpose Surface Protection and Repair Tape



- Hand Tearing-Straight and Easy
- Residue Free Removal
- Waterproof
- All-Weather Usage (-40°F to +200°F)
- Repositionable
- Highly Weather/UV Resistant
- Good Surface Protection
- Great for Quick Repairs

| PART NO. | COLOR | SIZE | RECOMMENDED FOR |
|----------|-------|-----------|------------------------------|
| GT1009GR | Green | 2" x 164' | Multi-Purpose - All Surfaces |

Extra UV Protection

Multi-Purpose Surface Protection and Repair Tape



- Hand Tearing-Straight and Easy
- Residue Free Removal
- Waterproof
- All-Weather Usage (-40°F to +200°F)
- Repositionable
- Highly Weather/UV Resistant
- Good Surface Protection
- Great for Quick Repairs

| PART NO. | COLOR | SIZE | RECOMMENDED FOR |
|----------|-------|-----------|---------------------|
| GT1008SW | White | 2" x 164' | Extra UV Protection |

Acrylic Flashing Tape

High Adhesion Acrylic Flashing Tape



- Perfect Flashing for Windows, Doors, & Deck Beams
- Hand Tearing-Straight and Easy
- Waterproof
- All-Weather Usage (-40°F to +200°F)
- Highly Weather/UV Resistant
- AAMA 7-11 Level 3 Class A Certified
- Great Performance and Ease of Use
- Cleanly Removes from Face-to-Face Adhesive Contact
- Available as a single roll or by the case

***Permanent Adhesion**

| PART NO. | COLOR | SIZE | RECOMMENDED FOR |
|------------|-------|-----------|--------------------------------|
| GT3040BK02 | Black | 2" x 65' | Acrylic/Flashing- All Surfaces |
| GT3040BK04 | Black | 4" x 65' | Acrylic/Flashing- All Surfaces |
| GT3040BK06 | Black | 6" x 65' | Acrylic/Flashing- All Surfaces |
| GT3040BK09 | Black | 9" x 65' | Acrylic/Flashing- All Surfaces |
| GT3040BK12 | Black | 12" x 65' | Acrylic/Flashing- All Surfaces |

Surface Protection

Repositionable Waterproof Surface Protection Tape



- Protects Surfaces from Scratches, Stains and Etching
- Applicable for All Stone Faces Including Marble and Limestone
- Can Be Used for Wet and Dry applications
- Easily Mark Tape with Ball Point Pen, Permanent Marker, China Marker, etc.

| PART NO. | COLOR | SIZE | RECOMMENDED FOR |
|----------|-------|-----------|--------------------------|
| BAB0650 | Black | 6" x 164' | Large Surface Protection |

EZ CLICK SYSTEM

NEXT-GENERATION SCREW-BASED TILE LEVELING SYSTEM



- Instant Screw Ejection Leveling System
- Supports Tile Thickness: 1/8" to 25/32" (3mm to 20mm)
- Levels and Spaces at The Same Time
- Tightens by Hand (No Tools Required)
- Minimum joint calibration: 1/32" (1mm)
- Ideal for Floor
- Proprietary Scratch-Prevention Edge
- Built-in spacer calibration: 1/32" (1mm), & 5/32" (4mm)
- *Patent Pending Design

Tightens and Releases by Hand
(No Tools Required)

The Quick and Reliable Leveling Cap



| PART NO. | SIZE | TYPE | COLOR | QTY |
|-----------|--------------------------|-------------------------|-------|-----|
| EZCLICKCP | | Screw Cap | Black | 50 |
| EZCLB10W2 | 1/32" (1.0mm) (2cm Tall) | Linear Joint Screw Base | White | 200 |
| EZCLB40B2 | 5/32" (4.0mm) (2cm Tall) | Linear Joint Screw Base | Black | 200 |

RSR-2000

RUST STAIN REMOVER IN GEL FORM



- Removes Common Rust Stains From Natural Stone Surfaces, Concrete, Brick, Terra Cotta, Mexican Tile, or Other Hard Porous Surfaces
- Specially Formulated To Work Extremely Fast
- Non-Hazardous Chemical Is Safe To Use and Will Not Harm The Environment
- Use On Floors, Countertops, Vertical Surfaces and Exterior Areas
- Available in 14oz Tube or Trial Size 1.4oz Bottle
- Tube Covers Approximately 4 sqft



| PART NO. | SIZE | CONTAINER |
|----------|---------------|-----------|
| RSR-400G | 14 oz. (400g) | Tube |
| RSR-040G | 1.4 oz. (40g) | Bottle |

Index

A

Adapter Hose 57
Air Hose 56
AIR-300 15
AIR-830 / AIR-834 16
Antique Brush Wheels 48
Apron 61

B

Blademaster 36

C

Ceramica EX 47
Contour Blade
 Granite & Eng. Stone 33
 Marble 33
 Porcelain/Cryst. Glass 32
Countertop Trim Kit 12

D

Dressing Stick 37
Drill Bit Guide 44
Dry Core Bits 42

E

ECC-125 13, 14
ECC-KIT 14
Eclipse II 25
Eclipse Q 25
Ecoguard C 50
Ecoguard CD 51
Ecoguard D 50
Ecoguard G Series 51
Ecoguard W Series 52
Electroplated Drill Bits 43
ESC-125 10
Exhaust Hose 57
EZ Click System 66

F

Flange Adapter 37
Flexible Backer Pad 53

G

Ground Fault
Circuit Interrupter 54
G-Tape 63
GV Backer Pads 53

H

Hand Pads 46
Hoses 56
Hot-Rod 34

K

Katana 26

M

Manifold System 55
Mobile Hose 57

P

Paver Tile Bullnose Kit 22
Plus 24
Pool Coping Kit 60
Porcellana 28
Porcellana For PRS 28
Profilers
 B-Series 39
 V-Series 40
 Z-Series 39
PSC-600 8
PSG-658 6
PT Cutter 35

Q

Q-Cut 27
Quad 24
Quad Adapters 37

R

Rescue 36
Rigid Backer Pad 53
Rotary Backer Pad 20
RSR-2000 66
Rust Inhibitor Oil 54

S

Sandpaper 47
Spike Ruler 37

U

Ultracut
 APR Series 31
 GPM Series 26

V

Vacuum Brazed
 Trimmer Bit 43
VDP-700 18
 Rotary Backer Pad 20
 Wool Pads 20
Vetro 29
Vetro For PRS 29
Vortex
 For Granite 30
 For Marble 30
VSP-320 21

W

Water Hose 57
Wet Blade Cutting Kit 58
Wet Core Bits 42
Wet Sanding/Polishing Kit 59
Wool Pads 20

Product Literature Catalogs

Alpha® provides product catalogs for all products to best serve the particular needs of our customers. Catalogs are available for applications such as Hand Tooling and Large Machine Tooling, as well as for specific industries such as stone, tile, construction, industrial, automotive, composites, glass and marine.

All of our catalogs are a convenient portable of size 5.5" x 8.5", and illustrate the tools and accessories needed for Cutting, Profiling, Grinding, Drilling, Polishing and Restoring all types of materials.

To request these catalogs, or for more information about our product line, visit our website at www.alpha-tools.com or contact us at 800-648-7229.



ALPHA® TOOL REPAIR

- Authorized repair centers available
- All tool repairs carry a 30-day warranty
- Quick turn-around time
- Technical support for repair and maintenance
- Order replacement tool parts directly from Alpha®
- Loaner program available

Visit our website to find a local center



Let's get social...



We are ready to connect with you on your favorite social media sites... Join Us Today!

 **Alpha Professional Tools®**

103 Bauer Drive • Oakland, NJ 07436
800-648-7229 • Fax: 800-286-0114

www.alpha-tools.com

