

Alpha[®] Pneumatic Air Polisher Instruction Manual

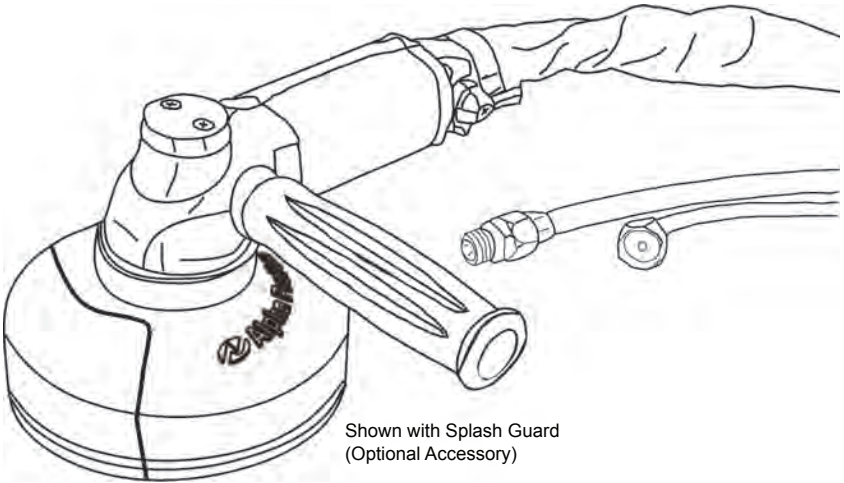

Shown with Splash Guard
(Optional Accessory)

Part No: AIR-658
Version 5

For repair information call:

Headquarters, Oakland, NJ — (800) 648-7229

Due to specially designed components this machine must be serviced only with genuine ALPHA[®] parts.

 **Alpha Professional Tools[®]**

►TABLE OF CONTENTS

Introduction.....	3
About the Symbols	3
Safety Instructions for Power Tools	4
AIR-658 Overview	6
Specifications	6
Accessories	7
Optional Accessories.....	7
Recommended Alpha® Accessories	7
Special Features.....	7
Tool Set-Up Information.....	8
Connection Fittings	8
Air Pressure and Volume	9
Lubrication	9
Polishing and Using The Tool	10
Spindle Size.....	10
Air Valve Lever.....	11
Water Control Valve	11
Silencer/Muffler	11
Reversible Side Handle	12
Water Supply Hose	12
Pneumatic Air Polisher Schematic.....	13
Air Polisher Parts List	14
Appendix A.....	16
Accessories and Factory Service	18
Product Registration	19

► INTRODUCTION

Thank you for purchasing an Alpha® Air Polisher. This polisher is the workhorse of a complete polishing system. A wide range of accessories help you perform many different tasks. This tool lets you grind, shape, bevel, contour and polish all kinds of granite and marble. You can easily change from one type of disc to another in just a matter of seconds. The tool is used with water to help you get the best possible finish, to reduce the health risks of dust, and to give the most savings in time and money from modern accessories. For your safety, please read this manual thoroughly before you start operating this polisher.

► ABOUT THE SYMBOLS

According to the hazard level, all safety notes in this manual are classified into “DANGER”, “WARNING”, and “CAUTION”.



DANGER! Death or serious personal injury is imminent when handling this polisher incorrectly.



WARNING! There is a possibility of death or serious personal injury when handling this polisher incorrectly.



CAUTION! There is a possibility of personal injury or property damage when handling this polisher incorrectly.

Note: In some situations, failing to observe WARNING notes could result in death or serious personal injury. Be sure to read and observe the safety notes to ensure safety and correct use of the polisher.

► SAFETY INSTRUCTIONS FOR POWER TOOLS

1. **KNOW YOUR POWER TOOL.** Read owner's manual carefully. Learn its applications and limitations as well as specific potential hazards particular to this tool.
2. **KEEP WORK AREA CLEAN.** Cluttered areas and benches invite accidents.
3. **AVOID DANGEROUS ENVIRONMENTS.** Keep work areas as dry as possible. Do not use tool in presence of flammable liquids or gases. Keep the area well lit.
4. **KEEP CHILDREN AND VISITORS AWAY.** All visitors should be kept a safe distance from the work area. Keep out of reach of children.
5. **DON'T FORCE TOOL.** It will do the job better and safer at the rate for which it was designed.
6. **WEAR PROPER APPAREL.** Do not wear loose clothing or jewelry as it can get caught in moving parts. Rubber gloves and insulated non-skid footwear are recommended. Wear protective covering to contain long hair.
7. **WEAR PROPER EYE PROTECTION.** Use safety glasses at all times. Also, use a face mask if work area is dusty.
8. **WEAR PROPER EAR PROTECTION.** Wear ear protectors when using for extended periods.
9. **WEAR PROPER RESPIRATORY PROTECTION.** A dust mask or other respiratory device should be used for applicable conditions.
10. **DON'T ABUSE WATER SUPPLY HOSE.** Don't carry tool by supply hose or expose to traffic areas where it can be crushed.
11. **ALWAYS SECURE WORK PIECE.** Use clamps or a vise to hold work. It's safer than using your hand and it frees both hands to operate tool.

12. **DON'T OVERREACH.** Keep proper footing and balance at all times.
13. **DISCONNECT TOOLS WHEN NOT IN USE.** Always disconnect tool before servicing; when changing accessories such as grinding wheels, backer pads, etc.
14. **REMOVE ADJUSTING KEYS AND WRENCHES.** Form a habit of checking to see that keys and adjusting wrenches are removed from tool before turning it on.
15. **MAINTAIN TOOLS WITH CARE.** Keep tools clean at all times for best and safest performance. Follow instructions for lubricating and changing accessories. Keep handles dry, clean and free of oil or grease. Inspect moving parts for alignment and binding as well as for breakage and improper mounting.
16. **AVOID ACCIDENTAL STARTING.** Don't carry a "connected" tool, or make adjustments, or change discs without making sure the air valve is in the off position to prevent the flow of air.
17. **USE ONLY RECOMMENDED ACCESSORIES.** The use of any accessories other than what is listed or recommended for this particular tool may be hazardous.
18. **KEEP HANDS AWAY FROM ALL MOVING PARTS.**
19. **USE SIDE HANDLES.** Supplied with tool for control and safety.
20. **USE RECOMMENDED GRINDING WHEELS ONLY.** Do not use conventional abrasive grinding wheels with this tool. Only use diamond grinding wheels which are rated for wet usage.
21. **STAY ALERT.** Watch what you are doing and use common sense. Do not operate tool when you are tired, or under the influence of medication or alcohol.

AIR-658 OVERVIEW

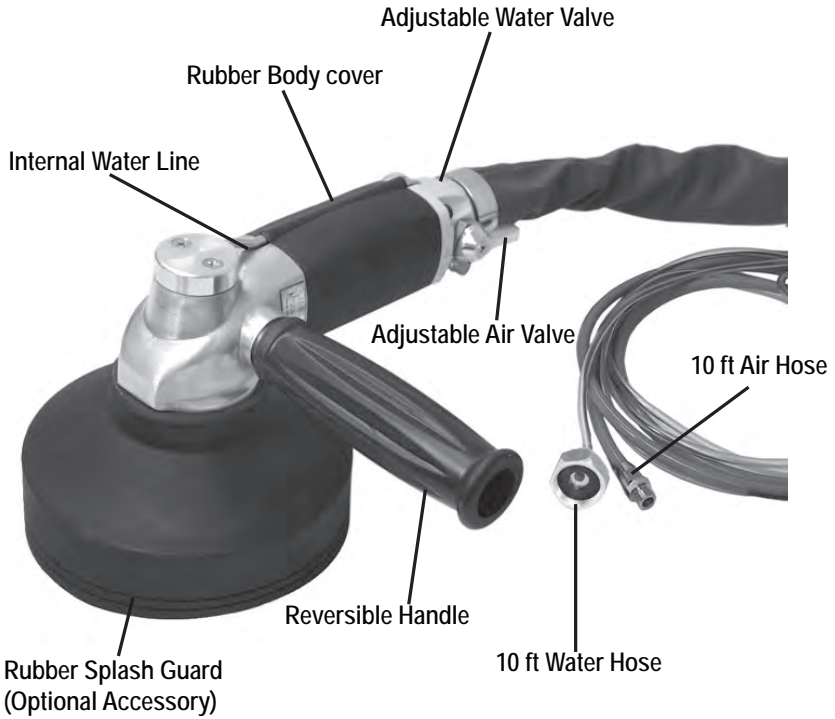

► SPECIFICATIONS

	RPM	Weight	Air Consumption	Air Pressure	Air Inlet	Water Inlet	Spindle
U.S.	No Load 4,000	2.64 lb	15 CFM	87 PSI	1/4" BSPP	1/8" BSPP	5/8"-11
METRIC		1.2 kg	0.42 M ³ /Min	6 Bars			

► **ACCESSORIES**

Water hose (10 ft / 3m)	1pc
Air hose (10 ft / 3m).....	1pc
Wrench (22mm)	1pc
Side handle	1pc
Lubrication Oil (1oz / 30 cc sample bottle).....	1pc

► **OPTIONAL ACCESSORIES**

Splash Guard (AWP-01)	1pc
C-Shaped Handle (AWP-21A)	1pc

► **RECOMMENDED ALPHA® ACCESSORIES**

Ceramica EX flexible diamond polishing discs, waterproof Sandpaper discs, Hook and Loop Backed Felt Wheels, Core Drill Bits, Twistouch Turbo and Profilers.

SPECIAL FEATURES

The Alpha® Air Polisher was designed with human engineering for operator comfort. It comes equipped with a silencer which reduces the level of noise as well as guiding the cold exhaust air away from an operator during the polishing process. This feature also eliminates excess lubricant dripping on the work piece. Portions of the body design are made with synthetic materials and covered with rubber to prevent fatigue and coldness to hands.

TOOL SET-UP INFORMATION

Unpack the tool carefully and study the helpful hints and warnings contained in this manual. Please take time to familiarize yourself with the features of the tool. Be sure to fill out the registration card enclosed, and mail it back to the distribution center today.

► CONNECTION FITTINGS

The air and water hose fittings on the back of this tool are BSPP (British standard parallel pipe or “G” thread). These fittings have parallel threads and seal off on the flat surface on the bottom of the thread. This type of fitting is usually supplied with an “O” ring or sealing ring which we replaced with the silencer.

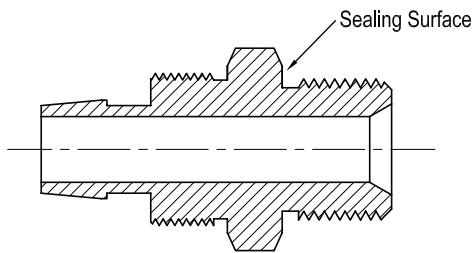
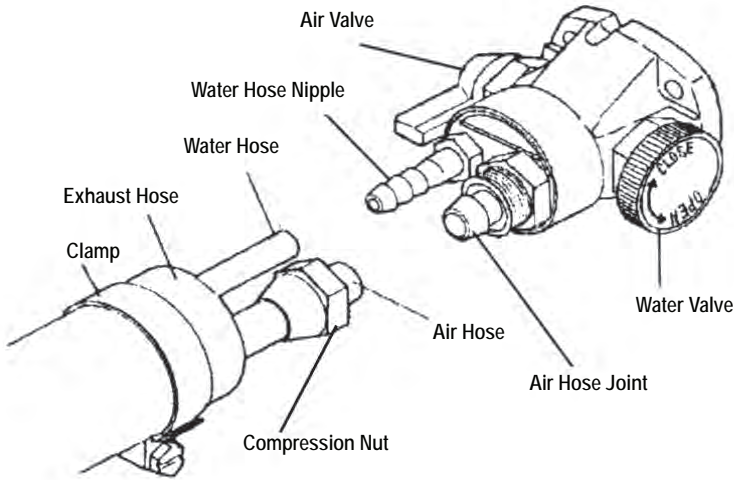

Parallel Thread

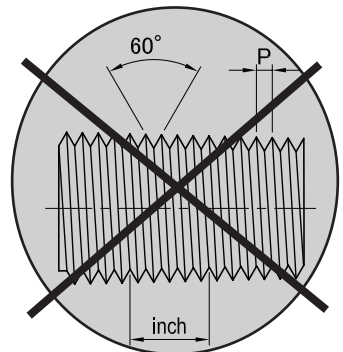

Taper Thread NPT

⚠ WARNING!

Trying to convert either fitting to an American standard pipe thread (NPT), which is tapered, will crack the end-case and is not covered under warranty.

► AIR PRESSURE AND VOLUME

The recommended air pressure for this tool is 87 PSI (6 BARS), however, the range of 85 to 90 psi is acceptable. Any pressure over 90 PSI will exceed the max speed rating of the rotor bearings causing them to overheat and lock up.

The most important factor in running this tool is the volume of air being supplied to the tool. The volume is the air consumption needed to run this tool at a constant speed under light downward hand pressure. The volume is measured in CFM (cubic foot per minute (ft³/min)). You need a minimum of 15 CFM per tool.

When choosing a compressor to run an AIR-658 polisher, we recommend a rotary screw type with a minimum of a 5hp motor/15-20 CFM and a 60 gallon tank, per tool. So if you want to run four tools, you will need a compressor with a 20hp motor capability of 80+ CFM and an 80 to 100 gallon storage tank. It is also very important to keep your air cool, dry, and clean, so look for a compressor with a refrigerated dryer and high-efficiency filter built in or purchase a separate air dryer and filter unit rated for your compressors CFM.

► LUBRICATION (Lube oil is used to protect the tool from rusting when not in use)

PROPER CARE AND LUBRICATION ARE IMPORTANT FACTORS IN PREVENTING THIS TOOL FROM RUSTING ON THE INSIDE WHEN NOT IN USE.

At the end of each workday, 2-3 drops of lubrication oil with rust inhibitor (included with each polisher) should be placed in the air inlet at the base of the tool. Rotate the spindle counter clockwise, by hand 3-4 revolutions. Reinstall the air hose and run the tool for a second or two to distribute the oil and mist the inside of the tool. (Replacement containers of oil may be purchased from Alpha® Professional Tools Part No. AIR-008).

Lubricating the tool before and during working is not needed. Excessive oil will turn to a tar-like substance inside the tool, causing the vanes to stick in the rotor and slow the tool down. This is the reason we do not recommend automatic oilers be used with this tool. Old or worn compressors, which emit oil through the air lines, can significantly shorten the life of the tool.

POLISHING AND USING THE TOOL

This tool and the Alpha® accessories approved for use with this tool are designed to be used under light downward hand pressure. You need to allow the polishing pads, core bits, and profilers to do their job. Applying excessive downward pressure to the tool will cause the vanes to wear out in the middle and fail prematurely.

► SPINDLE SIZE

The Alpha® AIR-658 air polisher features a 5/8"-11 spindle. This tool has been designed for portable/shop production and uses all modern accessories. It is very important that you do not run anything heavier than the recommended accessories on this machine. A drop of oil should be applied to the outside threads whenever attachments are changed to facilitate removal and prevent rust. A 22mm Spindle Wrench is provided to assist in changing accessories.

Maintenance and Usage Tip:

- Do not leave the tool submersed in water. This could expose the inner moving parts to moisture, which will shorten the life of the tool.
- Do not leave threaded accessories (backer pads, core drill bits, profilers) on the spindle of tool for extended periods of time; this may result in making it difficult to remove these accessories.
- Excessive force or impact to the spindle may result in premature failure of gears and/or bearings, which may not be immediately evident.

► AIR VALVE LEVER

The valve lever controls the flow of air through the tool. It has two positions- ON or OFF. Run the tool at the recommended range of 85-90 PSI, with the lever pointing to the ON position. This will produce 4,000 RPM. Do not try to vary the speed. The tool works best at full throttle only. Do not attempt to exceed the recommended speed by excess pressure. This will significantly shorten the life of the tool.

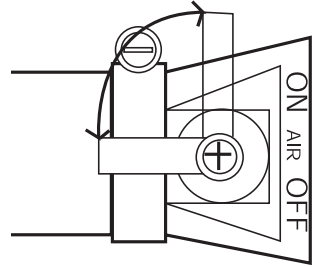

► WATER CONTROL VALVE

This valve lets you adjust the flow of water through the spindle. It may be used to shut off the water entirely when changing discs. When storing the tool overnight, open the valve and drain all water from the supply hose and tool.

► SILENCER / MUFFLER

To comply with OSHA Occupational Noise Exposure Standard Number 1926.52, this polisher is equipped with an internal Silencer System. When the polisher is operated correctly at 87 PSI, the sound level emitted should be less than 80 dBA. The internal Silencer System is also used to maintain a constant back pressure inside the tool; this helps prevent it from exceeding the recommended 4,000 RPM. The exhaust hose for this tool also helps to reduce the noise level by venting the exhaust air and residual air-line, thus eliminating the risk of excess lubricant dripping on the work piece. The new Silencer System is designed to allow small particle of contamination and dust to pass through, however if your air supply has particles larger than 1mm you will need to clean out the Silencer.

Maintenance and Usage Tip:

The Silencer is located on the rear of the polisher under the air and water fittings. A clogged Silencer would be indicated by a loss of power or lower RPM's from the tool. To clean the Silencer remove the air and water fittings, use a small screwdriver or pick to remove the hard plastic silencer and blow it out with compressed air from the outside (flat side of silencer). Reinstall the Silencer with the recessed side of the Silencer toward the tool, the Silencer should fit into the encase tightly, leaving a flat surface on the outside of the tool.

 **WARNING!**

Tools sent in for repair, where the body gasket or silencer is removed or modified, are not covered under our Limited Warranty!

► REVERSIBLE SIDE HANDLE

Attach the handle into the threaded socket on either the left or right side of the tool. A locknut is slipped onto the threads to keep the handle safely in position.

Maintenance and Usage Tip:

Do not apply more force or pressure than the force created by the weight of the polisher itself. The polishing discs are designed to work properly under light downward hand pressure. Applying excessive force or pressure may damage the disc and could shorten the life of the tool.

► WATER SUPPLY HOSE

This hose may be connected to any garden hose. The hose is composed of a special material to avoid kinks. Replacements are available should the hose become damaged, Part No. 133229.

ALPHA® PNEUMATIC AIR POLISER SCHEMATIC

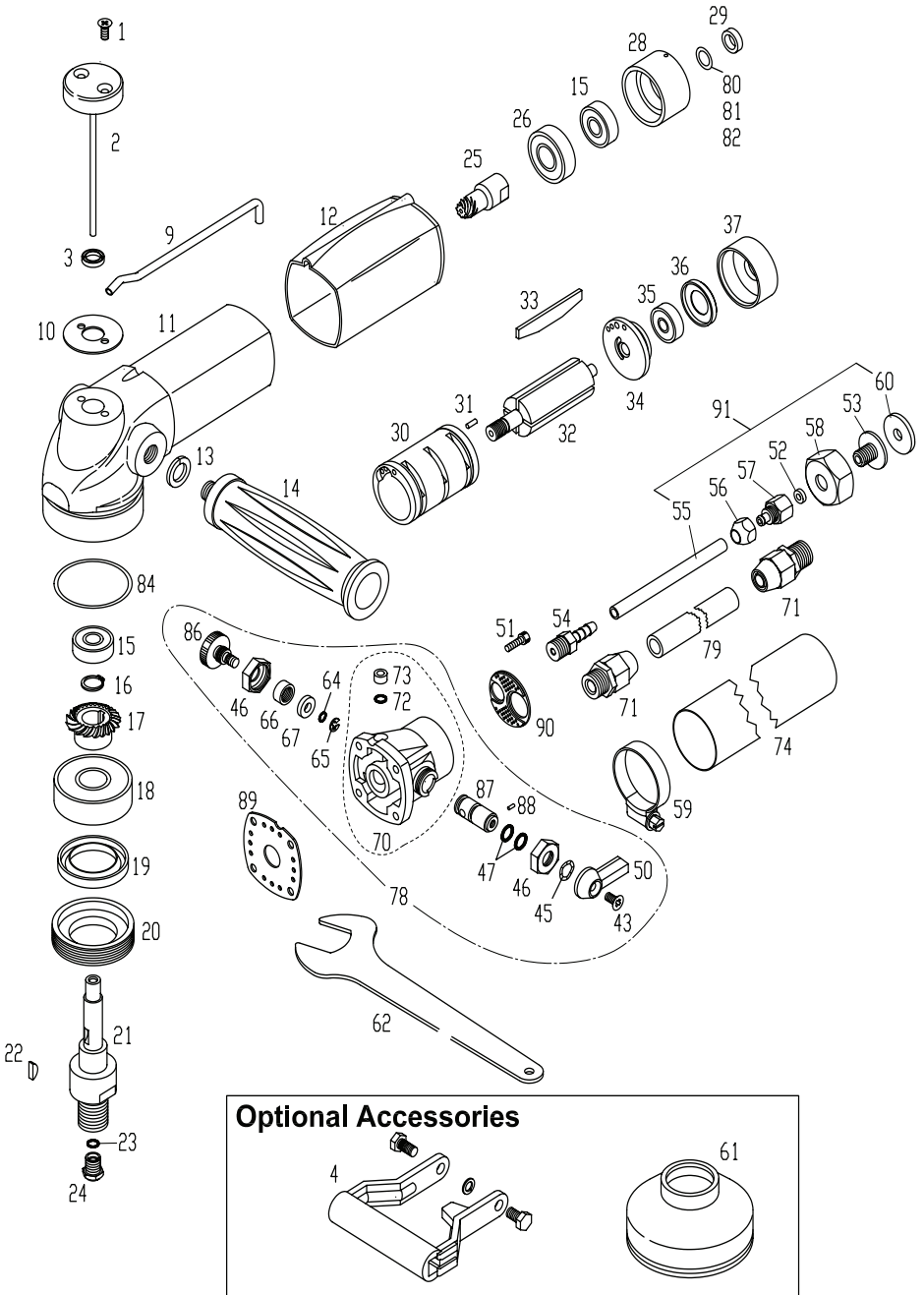

► ALPHA® PNEUMATIC AIR POLISHER PARTS LIST (VERSION 5)

DRAWING NO.	PART NO.	ITEM DESCRIPTION	QUANTITY
1	658-01	Screw M4x10	2
2	658-02	Pipe-joint Assembly	1
3	516-44	Oil Seal	1
4	AWP-21A	C-Shaped Handle for Air Tools*	1
9	658-09	W-pipe	1
10	658-10	Head Packing	1
11	658-11	Body	1
12	658-12	Body Cover	1
13	658-13	Spring Washer M10	2
14	658-14	Grip	1
15	516-20	Bearing 608 ZZ	1
16	658-16	Snap Ring	1
17	658-17	Spiral Bevel Gear	1
18	516-48	Bearing 6302 ZZ	1
19	658-49	Oil Seal	1
20	658-50	44 Nut	1
21	658-21	Spindle 5/8-11 Thread	1
22	658-22	Half Moon Key	1
23	658-23	O-ring	1
24	658-24	5/8 Nozzle	1
25	658-25	Spiral Bevel Pinion	1
26	516-18	Bearing 6001 ZZ	1
28	658-28	F-Bearing Case	1
29	658-29	Rotor Spacer	1
30	658-30	Cylinder (Inc. Part# 658-31)	1
31	658-31	Spring Pin	1
32	658-32	Rotor	1
33	516-25	Vane (4 Piece Set)	1
34	516-26	R-Bearing Case	1
35	516-27	Bearing 626 ZZ	1
36	516-28	Bearing Cap	1
37	658-37	Air Inlet Case	1
43	658-43	Screw M4x10	1
45	658-45	Wave Washer	1
46	658-46	Nut M14	1
47	658-47	O-ring	2
50	658-50	Valve Lever	1

► ALPHA® PNEUMATIC AIR POLISHER PARTS LIST (VERSION 5)

DRAWING NO.	PART NO.	ITEM DESCRIPTION	QUANTITY
51	658-51	Screw M4x15	4
52	133236	Compression Washer	1
53	133230	Sleeving Connector	1
54	658-54	Nipple	1
55	133229	Water Hose 8mm OD x 10ft (3m)	1
56	133231	Compression Nut	1
57	133234	Adapter Fitting	1
58	133232	Water Hose Adapter	1
59	658-59	Clamp	1
60	133233	Gasket 24.5x7x3	1
61	AWP-01	Rubber Splash Guard*	1
62	658-62	Wrench 22mm	1
64	658-64	O-ring	1
65	658-65	R-ring	1
66	658-66	Nut M8	1
67	658-67	Washer 05	1
70	658-70	Endcase w/Bushing (Inc. Part# 658-72 & 658-73)	1
71	516-79-2	Air Hose Joint 1/4" BSPP	1
72	658-72	O-ring	1
73	658-73	Bushing 07	1
74	658-74	Exhaust Hose	1
78	658-78	Complete Endcase Assembly	1
79	516-79-1	Air Hose 10mm OD x 3M	1
80	658-80	Shim 01mm x 12mm OD	1
81	658-81	Shim 03mm x 12mm OD	1
82	658-82	Shim 05mm x 12mm OD	1
84	658-84	Shim 01mm x 84mm OD	1
86	658-86	Water Valve	1
87	658-87	A-Valve (Inc. Part# 658-88)	1
88	658-88	Needle Pin	1
89	658-89	Body Gasket	1
90	658-90	Silencer	1
91	133287	Water Hose Assembly	1
Not Shown	AIR-008	Air Polisher Lube Oil 8oz	1
Not Shown	ST055	44-Nut Wrench	1

APPENDIX A —OPTIONAL ACCESSORIES

► SPLASH / SAFETY GUARD

For operator comfort and safety, a splash guard is recommended. The guard should remain in place for all grinding and polishing operations. (Splash Guard — Part No. AWP-01)

► C-SHAPED HANDLE / REVERSIBLE SIDE HANDLE

The C-Shaped handle: During use with Alpha® Core Bits and Alpha® Profilers, use of the “C-Shaped” handle is recommended. The C-Shaped handle will allow operator to have more control and ease of operation during these applications. (C-Shaped handle — Part No. AWP-21A)

► CUSTOMIZING THE SPLASH GUARD

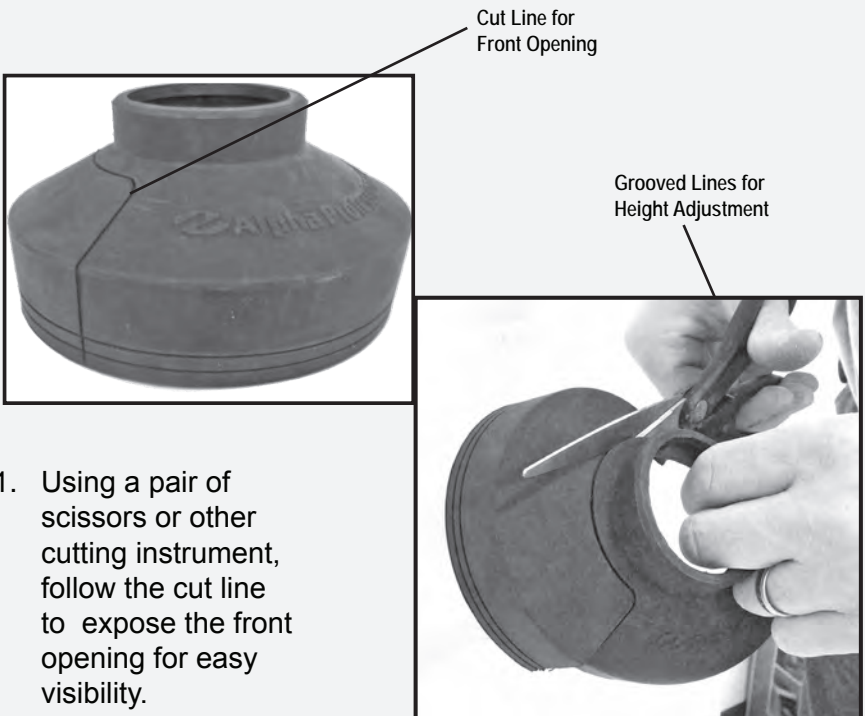

2. Choose the desired height according to the application to be performed and cut along the grooved cut lines to adjust the height.



3. Install the rubber splash guard onto the tool so that the lip on the splash guard fits into the groove on the tool and the cutout is around the water fitting.

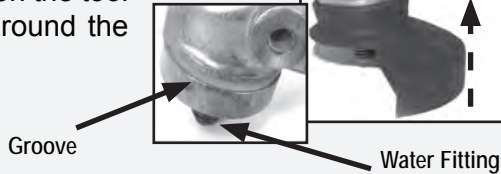

► INSTALLING C-SHAPED HANDLE

When used with Alpha® Core Bits and Alpha® Profilers, the “C-Shaped” handle allows the operator to have better control and stability during operation. (Part No. AWP-21A).



1. Place flat washer over hole pattern, as shown above.

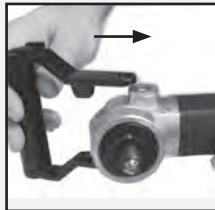

2. Slide C-Shaped handle over flat washer and align holes.



3. Insert bolt and lock washer into hole and tighten by hand.



4. Using a wrench, tighten bolts to securely attached the C-Shaped handle. Repeat steps for the opposite side.



C-Shaped Handle during Drilling Application



C-Shaped Handle during Profiling Application

► ACCESSORIES AND FACTORY SERVICE

All the accessories can be purchased at a local distributor in your area. For more information concerning Alpha® Air Polisher and factory service, please contact the Alpha® distribution centers listed below.

COMPANY HEADQUARTERS:	Alpha Professional Tools® 103 Bauer Drive Oakland, NJ 07436
Hours of Operation:	8:30 a.m. – 5:00 p.m. EST
Telephone Number:	201-337-3343
Toll-Free Number:	800-648-7229

or visit us on the web at: www.alpha-tools.com

Limited Warranty of Alpha® Air Polisher (AIR-658)

Alpha Professional Tools® warrants this product against defects in material and workmanship for a period of 90 days from the date of original retail purchase (proof of purchase required). If Alpha Professional Tools® receives notice of such defects during the warranty period, our obligation assumed under this warranty is limited to the repair or replacement of parts, without charge. This warranty does not apply to tool accessories.

For Warranty Claims: Send complete tool with all your information and details of the problem to the Alpha Professional Tools®, transportation prepaid. Do not send tool accessories.

PRODUCT REGISTRATION CARD

Model No.

Serial No.

Company Name: _____

Name: _____

Address: _____

City: _____ State: _____ Zip: _____

Telephone: _____

Purchase Date: _____

Dealer's Name: _____

Note: Serial & Model Number must be included for proper registration.



Alpha Professional Tools®

(800) 648-7229



Register online at:
www.alpha-tools.com/productregistration.aspx

Mail or Fax to:
Alpha Professional Tools®
103 Bauer Drive, Oakland, NJ 07436
Fax: 800-286-0114

Photocopy of product registration form will be accepted.



103 Bauer Drive, Oakland, NJ 07436 • 800-648-7229 • Fax: 800-286-0114
www.alpha-tools.com

Copyright © 2013 Alpha Professional Tools. All rights reserved.

06/2013
