Alpha[®] Black Belt Rail Saw Instruction Manual



* Shown with optional 8-roller table extension (BBS8ROLL) & Side Counter-cut (BBSUSIDE)

Part No: BBS-012
Version 06/2024

 **Alpha Professional Tools**[®]

16 Park Dr Ste 9, Franklin, NJ 07416 • 800-648-7229
www.alpha-tools.com

TABLE OF CONTENTS

1 - INTRODUCTION.....	4
1.1 – About the Symbols	4
1.2 – Manufacturer and Machine Identification	4
2 - TECHNICAL INFORMATION	5
2.1 – General Machine Description.....	5
2.2 – Technical Data	6
2.3 – Noise Level	7
2.4 – Vibration Level	7
2.5 – Accessories Description.....	7
3 - SAFETY INFORMATION	8
3.1 – General	8
3.2 – Improper Use	8
3.3 – Safety Label Description.....	9
3.4 – Safety Devices.....	9
3.5 – Perimetric Work Areas.....	10
3.6 – Safety Labels Position.....	10
4 - INSTALLATION INFORMATION	10
4.1 – Installation	10
4.2 – Accessories Installation	11
4.3 – Blade Replacement.....	12
4.4 – Electrical Connection.....	13
4.5 – Locking of the Cutting Head for Transportation	13
5 – TUNING INFORMATION	14
5.1 – Tuning Recommendations	14
5.2 – Setting The Cutting Width	14
5.3 – Setting The Cutting Angle	15
5.4 – Setting For 45 Degree Cuts.....	15
6 – USAGE	16
6.1 – Recommendation For Usage And Operation.....	16
6.2 – Tooltips	16

6.3 – Start / Stop	16
6.4 – Filling And Emptying The Water Tank	17
6.5 – Machine Usage.....	17
6.5.1 – Straight Cut	18
6.5.2 – Diagonal Cut.....	19
6.5.3 – Setting For 45 Degree Cut	21
6.5.4 – Hole Cut	22
6.6 – Long inactivity	24
7 – MAINTENANCE INFORMATION.....	24
7.1 – Maintenance Recommendations	24
7.2 – Maintenance Schedule Table.....	24
7.3 – Sliding Wheels’ Adjustment	25
7.4 – Blade Parallelism Adjustment	25
7.5 – Blade Perpendicularity Adjustment	26
7.6 – Pump Maintenance	26
7.7 – Machine Cleansing.....	26
8 – TROUBLESHOOTING	26
8.1 – Problems, Causes And Remedies	31
9 – ATTACHING THE TIRE WHEEL	27
10 - WARRANTY	27

1. INTRODUCTION

Thank you for purchasing the Alpha® Black Belt Wet Rail Saw for large format tiles (BBS-012). Professional Quality Rail Saw, Ideal for Cutting Ceramics, Porcelain, Glass Panel and other Materials. Please read this instruction manual thoroughly to ensure safe and correct use of the electric wet saw. Keep this manual in a place where operators can access it easily whenever necessary.

1.1 – ABOUT THE SYMBOLS

	DANGER-WARNING	Indicates situations of serious danger that if ignored may cause risks for people health and safety.
	CAUTION-WARNING	Indicates that it is necessary to take precautions to avoid endangering people health and safety and causing economical damages.
	IMPORTANT	Indicates technical information of particular relevance that should not be overlooked.

1.2 – Manufacturer And Machine Identification

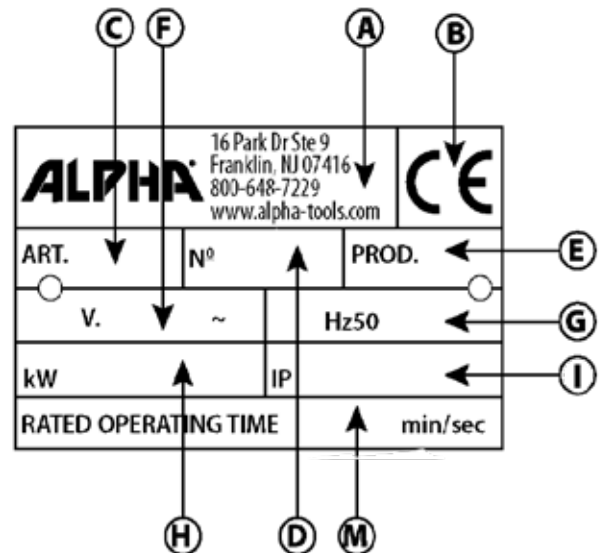

- A. Identification of Manufacturer and His Address
- B. CE Brand-Mark of Conformity
- C. Machine Model
- D. Registration Number
- E. Manufacturing Year

- F. Electrical current frequency
- G. Electrical Current Voltage
- H. Declared Power
- I. Grade of Protection

2 - TECHNICAL INFORMATION

2.1 – General Machine Description

- The cutting machine, henceforth machine, has been designed and built to perform cutting and mitring on tiles for wall coverings and flooring prior to laying, and cutting bricks, stones and porcelain materials.
- This machine is normally installed in craft and industrial environments, sheltered from the weather.



Main components:

- A. **Support Feet:** to guarantee stability to the machine.
- B. **Work Top:** to support tiles during cut operation.
- C. **Cutting Group:** to perform cut operations or tile perforations.
- D. **Water Pump:** to push water through its circulation path.
- E. **Basin:** to contain water used for cutting blade refrigeration.
- F. **Electrical Switch:** to start the cutting blade rotation. It features magneto-thermic protection against overload.

2.2 – Technical Data

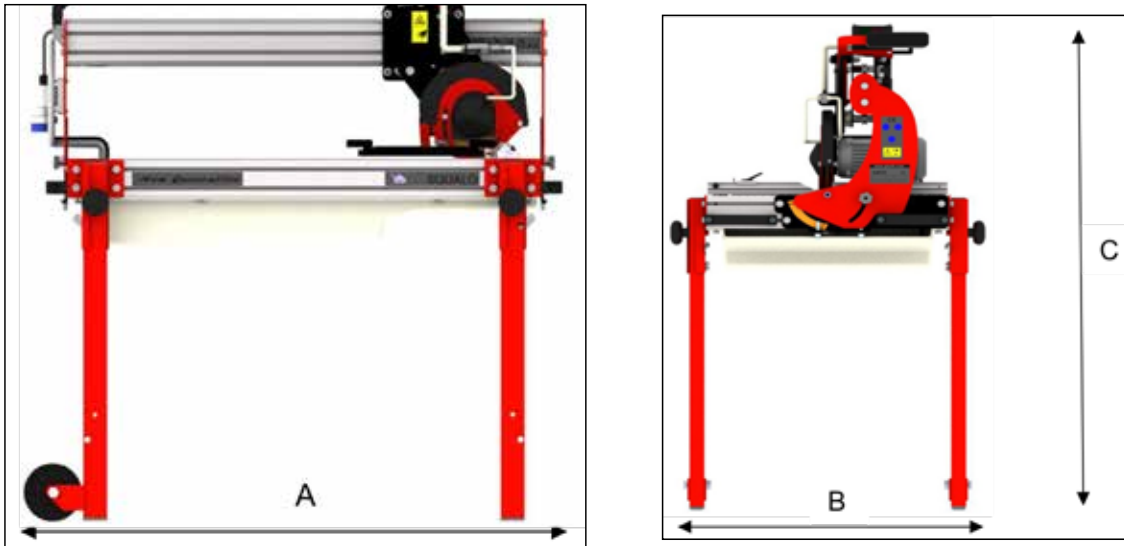

Physical sizes	
Weight (lbs / kgs)	231 lbs (105 kgs)
Size A (in. / mm)	80.70 in (2050 mm)
Size B (in. / mm)	29.53 in (750mm)
Size C (in. / mm)	57.09 in (1450mm)
Cut Specifications	
Blade diameter (in. / mm)	12 in / 14 in (300mm / 350mm)
Max cut length (in. / cm)	51 in (130cm)
Cut depth (mm)	5 in (125mm)
Cutting Blade(s)	
Internal bore (in. / mm)	1" & 60mm (25.4mm / 60mm)
External diameter (in. / mm)	12 in / 14in (300mm / 350mm)
Electrical Engine	
Voltage (V)	230 V
Frequency (Hz)	50 Hz
Declared power (HP / kW)	3 HP
Protection grade (IP)	55 (IP)
Rotation speed (rev/min)	2800 RPM
Water Pump	
Voltage (V)	230 V
Frequency (Hz)	50 Hz
Declared power (W)	13 W
Protection grade (IP)	68 (IP)
Range (l/h)	400
Electrical Plug	
Type	16A 120V ~ 2P+T
Environmental Conditions	
Min. Temperature	41° F (5° C)
Max. Temperature	95° F (35° C)
Max. relative humidity (Rhu)	90%
Max. altitude (meters asl)	1000

2.3 – Noise Level



Caution - Warning

Ear-muff protection is compulsory.

The table below reports noise levels depending on operative condition and measurement points. This measurement was performed in respect of CEE rules 89/392, 91/368, ISO 3746.

Lw - Sound power level 96 dB (A)

Leq - Equivalent sound pressure level at operator's ear 93,7 dB (A)

2.4 – Vibration Level

During its use, the machine presents the following vibrations levels. This measurement was performed in respect of ISO rules 5349.

Body, head, arms and hands 0,1 m/sec²

2.5 – Accessories Description

The manufacturer makes a number of accessories available that increases this machine's performance and versatility.

Fat Tire



PART # BBS14WHL

Optional Accessories (Sold Separately)

Side Countercut



PART # BBSUSIDE

8-Roller Extension Table



PART # BBS8ROLL

3 - SAFETY INFORMATION

3.1 – General

- During the design and construction phase the manufacturer paid special attention to issues that may cause safety hazards to the health of people interacting with the machine. In addition to complying with all relevant laws, they have adopted all relevant “engineering rules and best practices”.
- The purpose of this information is to sensitize users to pay special attention and avoid any risks. Caution is yet irreplaceable. Security is also in the hands of all the operators that interact with the machine.
- Carefully read the instructions in this manual and those applied directly on the machine, in particular those regarding safety. A bit of time spent reading will save you from unpleasant accidents, it is always too late to remember what should be done when it has already happened.
- Pay attention to the meaning of all symbols found on labels. Their shape and colour are important for safety. Keep them readable at all times, and comply with the information provided. Do not tamper with, sidestep, eliminate or bypass any installed safety device. Failure to comply with this requirement may cause serious risks to people health and safety.
Even after thoroughly studying the manual, upon machine first use do simulate some manoeuvres to help yourself identify machine controls and functions.
- Use the machine only for the purposes intended by the manufacturer. Its improper use can pose risks to people health and safety, and produce economic damage.
- All maintenance operations that require precise technical skills or special skills may only be carried out by qualified personnel with recognized expertise and experience in that specific field of intervention.
- During operation, always wear all clothing and/or personal protection equipment mentioned in the instructions provided by the manufacturer, and those required by the laws concerning safety at work.
- Before using the machine, always verify that no one is near the work area. Pay special attention to children and people with limited physical abilities.

3.2 – Improper use

- Do not use the machine to cut materials different from those specified by the manufacturer.
Do not use cutting discs different from the standard indicated by the manufacturer.
It is absolutely forbidden to use this machine in explosive environments.

3.3 – Safety label description

Some of these signals are applied to the machine, their position is indicated in the paragraph “Safety Labels Positions”.



Upper limbs cut danger: The diamond blade has sharp edges.



General danger: Before performing any maintenance, disconnect the power supply connector.



Gloves required: Wear protective gloves during machine use



Ear muffs required: Wear protective headphones during machine use.



Safety shoes required: Wear appropriate footwear during machine use



Protective eyewear required: wear safety goggles during machine use.

3.4 – Safety Devices

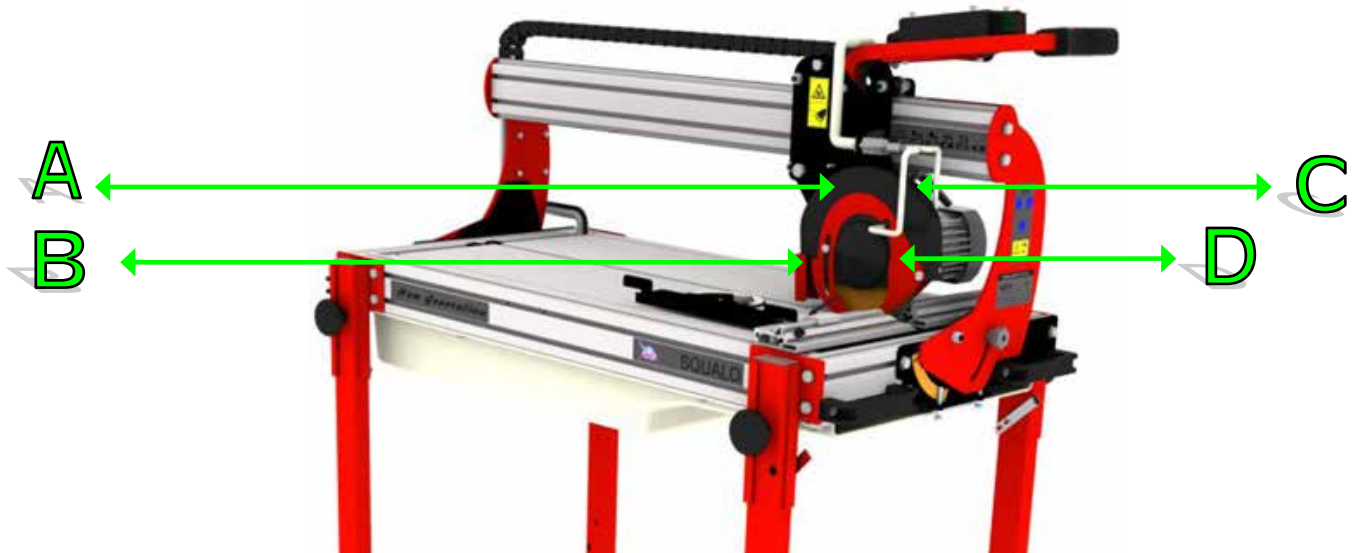

The picture shows the position of the safety devices:

- A. **Safety Cover:** to protect the operator from cutting blade contact.
- B. **Splash Guard:** to protect the operator from cutting debris.
- C. **Safety Lock:** to lock/prevent cutting group movement.
- D. **Side Blade Guard:** to protect the operator from blade contact.

3.5 – Perimeter Work Areas

The picture shows operative areas:

1. Command area of the operator
2. Perimetric area
3. Dangerous area

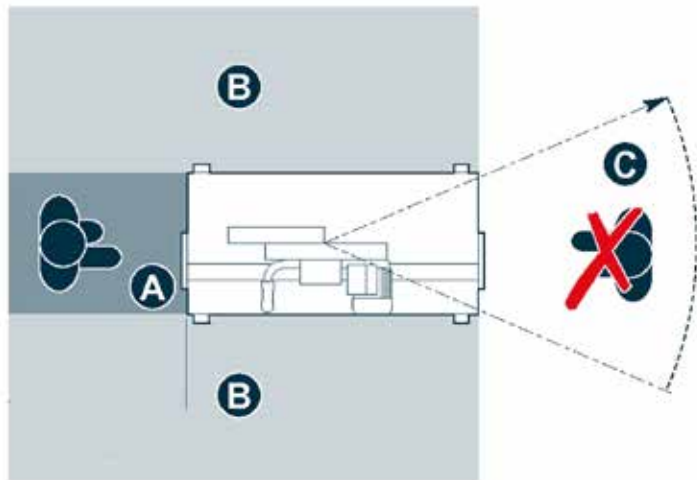

3.6 – Safety Labels Position

The illustration shows the position of the safety labels. Their meaning is explained under: “Safety labels description.”

	IMPORTANT
Make sure that labels are always readable - otherwise replace them onto their original position.	

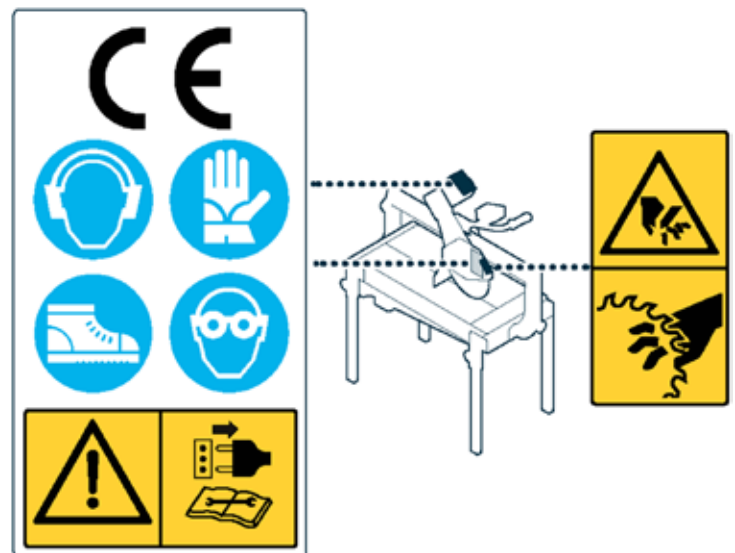

4 - INSTALLATION INFORMATION

4.1 – Installation

	IMPORTANT
All installation steps must be considered, since the beginning of the overall project. Before you begin these steps, as well as the definition of the installation area, you should, if necessary, implement a “safety plan” to ensure the safety all directly involved people, and the strict application of all relevant laws, with particular reference to those about mobile sites. For this operation, always wear protective gloves and safety shoes.	

The installation area must be provided with all the power connections and shall be adequately illuminated. The floor must be a steady, even surface to ensure proper support to the machine.

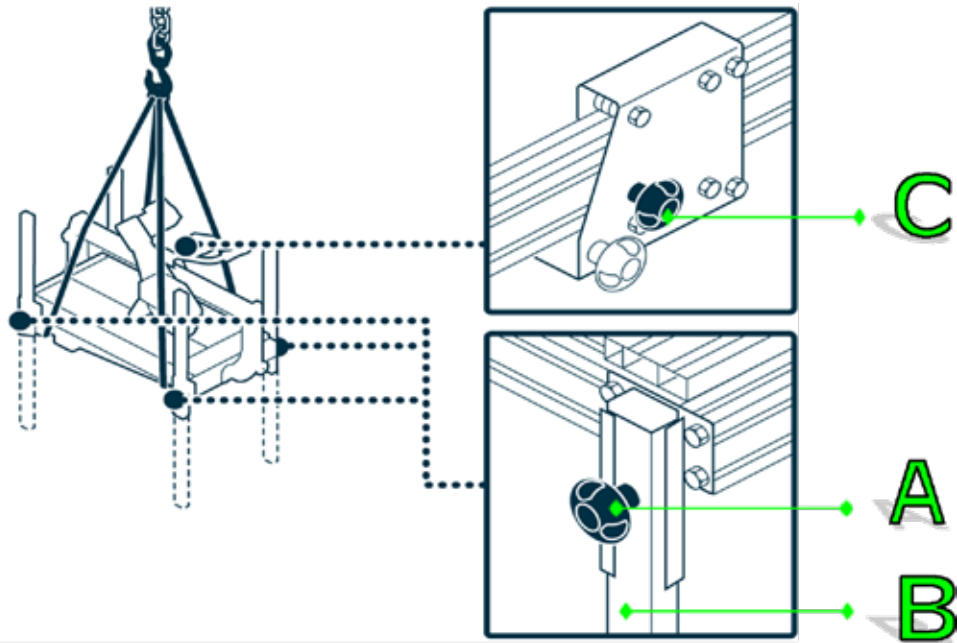

For this kind of operation, please proceed as follows:

1. Lift the machine as you can see in the picture.
2. Unscrew (A) knob, lower (B) support-foot and retighten the knob.
3. Repeat the same operation for all feet.
4. Lay the machine on the floor.
5. Remove (C) knob in order to unlock cutting group movement.



CAUTION - WARNING

Make sure that legs are securely fastened to the chassis.

4.2 – Accessories Installation

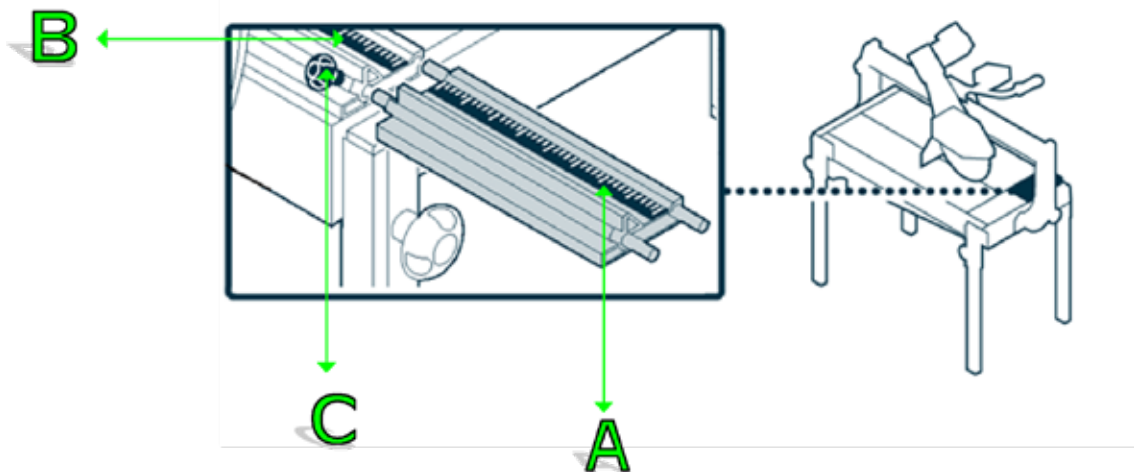

Please proceed as follows.

1. Put (A) extension onto the (B) guide.
2. Tighten the (C) knob in order to lock the extension in position.

4.3 – Blade Replacement

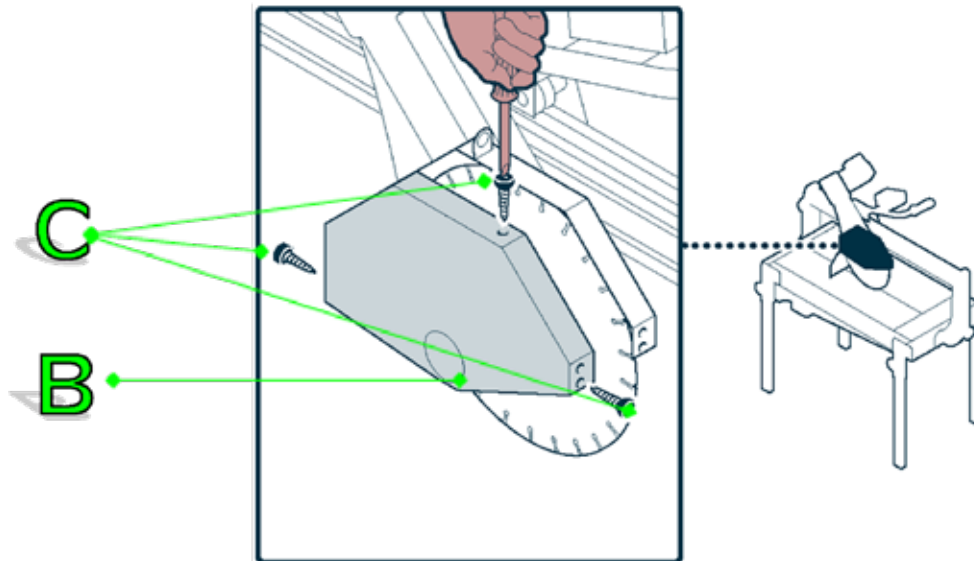

Please proceed as follows:

1. Remove the **(C)** screws and remove the **(B)** disk protection.

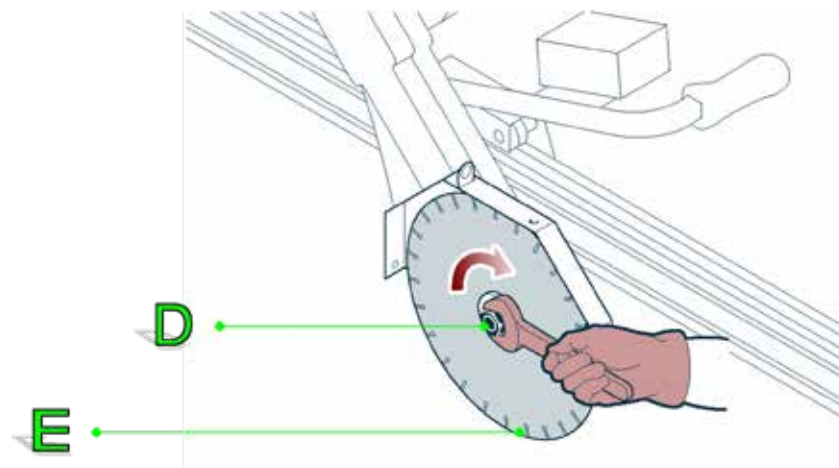

2. Unscrew the **(D)** nut (Using provided Wrench and Hex Wrench).
3. Remove the **(E)** cutting blade and replace it. Remember to check rotation's direction.
4. Re-tighten the **(D)** nut.
5. Spin the blade manually to check its correct seating.
6. Refit the **(B)** disk protection.
7. Thread the water pipe back into its hole.





IMPORTANT

After the replacement, turn the machine ON then immediately OFF – to check that the disk spins in the right direction, thus avoiding potential operator risks and machine damage.

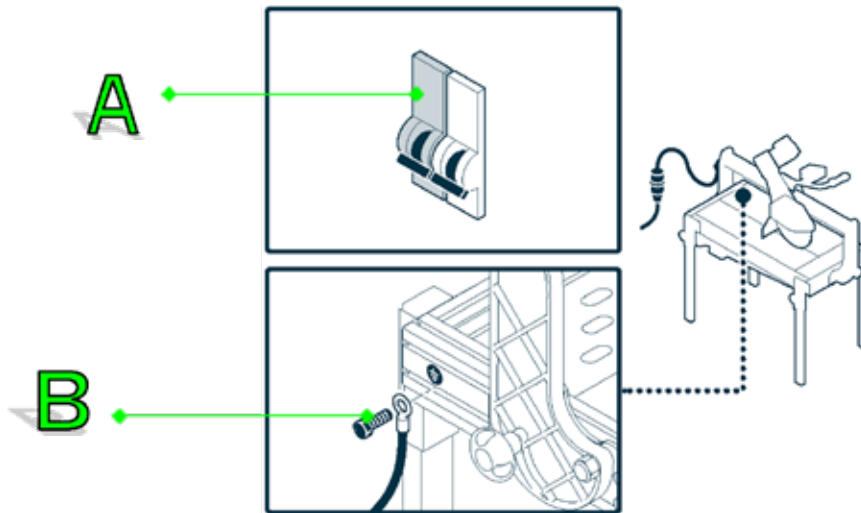
4.4 – Electrical Connection



1. It is recommended to install a circuit breaker (**A**) upstream from the machine power supply.
2. Connect the electrical plug to the plant's mains supply .
3. Connect the ground cable to the (**B**) ground terminal on the machine.

 IMPORTANT	Check that line voltage (V) and frequency (Hz) correspond to those of the machine (see nameplate and wiring diagram). Check that the system grounding, which you have to connect the machine to, is efficient.
 IMPORTANT	Always use plugs featuring at least 16A - 6H / 120V - 2P+T standards.

4.5 – Locking Of The Cutting Head For Transportation



1. Slide Cutting Head so the Locking Bracket contacts with the Hex Bolt.



- Loosen and slide the Knob Bolt into the Locking Bracket position. Re-tighten the Knob Bolt to secure the Cutting Head for transportation.

5 – TUNING INFORMATION

5.1 – Tuning Recommendations



IMPORTANT

Before doing any work or taking any action on the machine, always turn main power OFF.

5.2 – Setting the Cutting Width

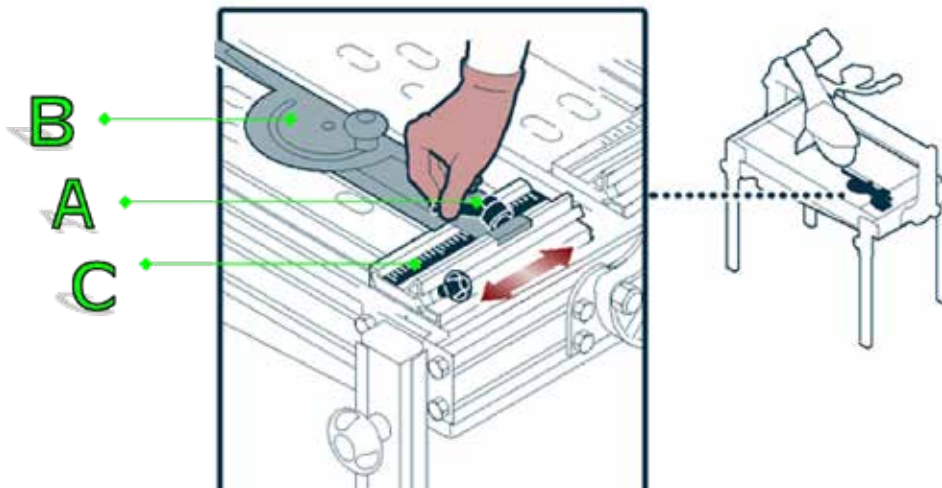

Please proceed as follows.

- Loosen the (A) knob.
- Slide the (B) square until reaching the desired horizontal displacement, readable on the (C) inch/centimeter gauge.
- Re-tighten the (A) knob at the end of the operation.

5.3 – Setting the Cutting Angle

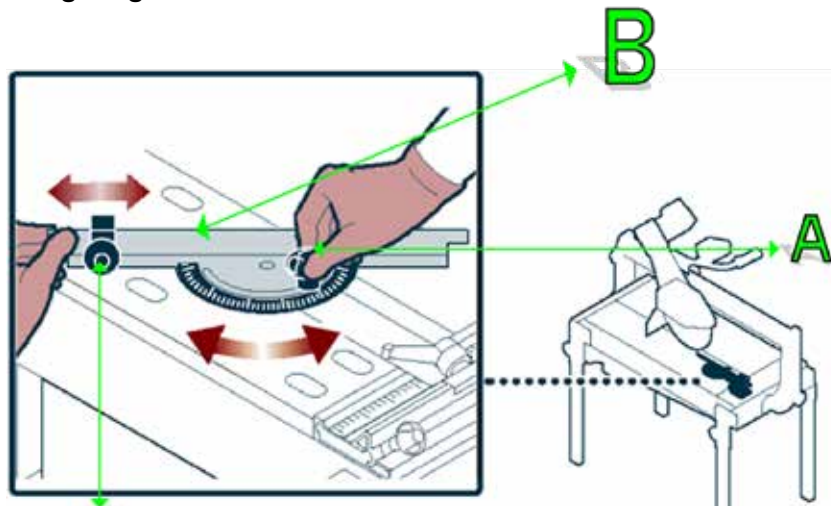

Please proceed as follows:

1. Loosen the **(A)** knob.
2. Rotate the **(B)** goniometer until reaching the desired angle value.
3. Re-tighten the **(A)** knob at the end of the operation.
4. Adjust the position of the **(C)** stopper adapting it to cut material size.

5.4 – Setting for 45 Degree Cuts

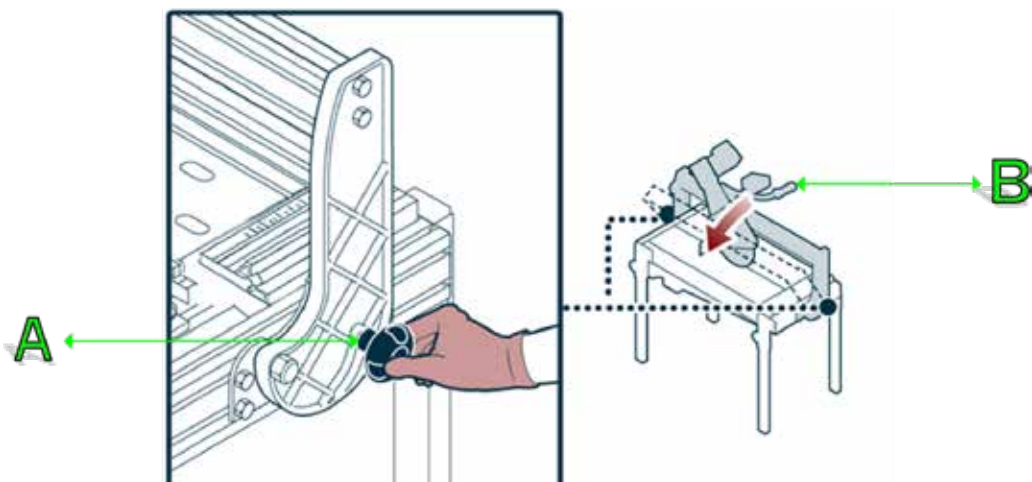

Please proceed as follows:

1. Loosen the **(A)** knobs on both sides of the working chassis.
2. Tilt the **(B)** bridge on its side, all the way to its 45° position.
3. Re-tighten both **(A)** knobs at the end of the operation

6 – USAGE

6.1 – Recommendation For Usage And Operation



IMPORTANT

The incidence of accidents resulting from the use of machines depends on many factors that are not always can be prevented and controlled. Some accidents can be caused by environmental factors not predictable, others strongly dependent on user behaviour. They, as well as being authorized and suitably documented, if necessary, before the first use, will simulate some manoeuvres to identify the controls and functions. Implement only the uses specified by the manufacturer and do not tamper with any device to obtain services other than those provided. Before use, check that the safety devices are perfectly installed and efficient. Users, as well as committing to meet these requirements, they must apply all safety rules and carefully read the description of the controls and the preparation for the use of the machine.

6.2 – Tooltips

The picture shows the command position on the machine

A. Switch

To activate and deactivate the rotation of the cutting blade and the pump.

Pos.(I): blade rotation activated

Pos.(0): blade rotation deactivated

B. Water tap:

To adjust the water flow.

Pos.1: tap open

Pos.2: tap closed

Intermediate positions between “open” and “closed” regulate water flow.

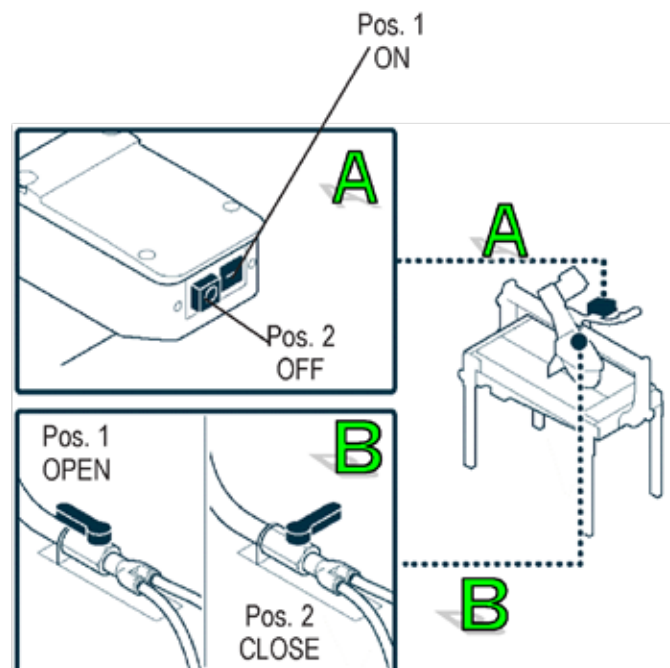

6.3 – Start / Stop

Start

Push on (I).button

Stop

Push on (0) button

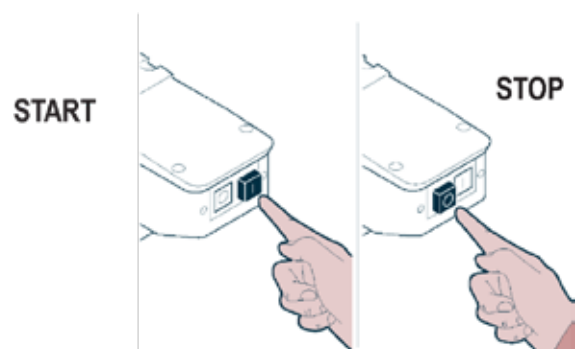

DANGER - CAUTION

Even after engine is turned off, cutting disk keeps spinning for a few seconds.

6.4 – Filling and emptying the water tank

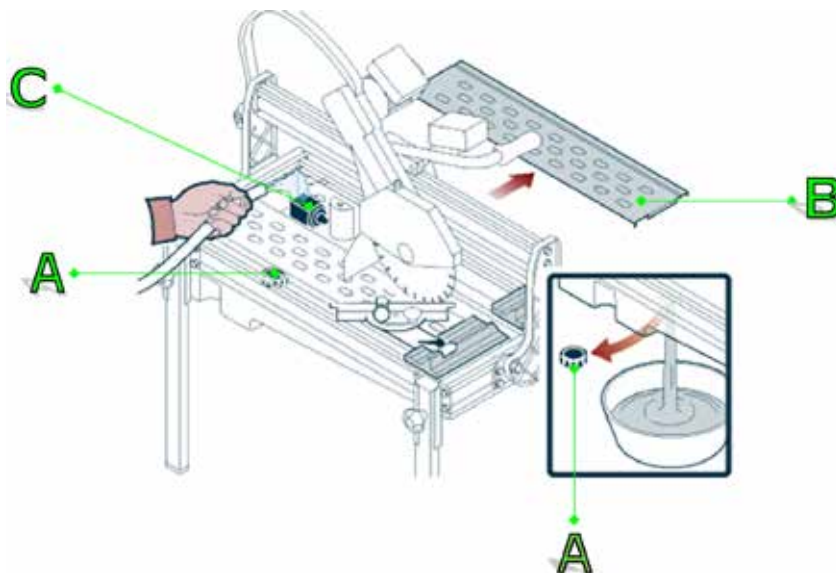

Filling

1. Make sure the (A) tank cap is screwed in tight.
2. Remove the (B) working table.
3. Put water into the tank until the pump is fully submerged (C).

Emptying

4. Place a bucket of adequate capacity under the tank, then unscrew its (A) cap.

6.5 – Machine Usage

With this machine it is possible to perform the following cuts.

- Straight cut
- Diagonal cut
- 45 Degree (Miter Cut)
- Square holes



DANGER - CAUTION

Even after engine is turned off, cutting disk keeps spinning for a few seconds.

6.5.1 – Straight Cut



5. Remove the **(A)** knob
6. Loosen the **(B)** knob and bring the cutting group in its full-lowered position.
7. Re-tighten the **(B)** knob

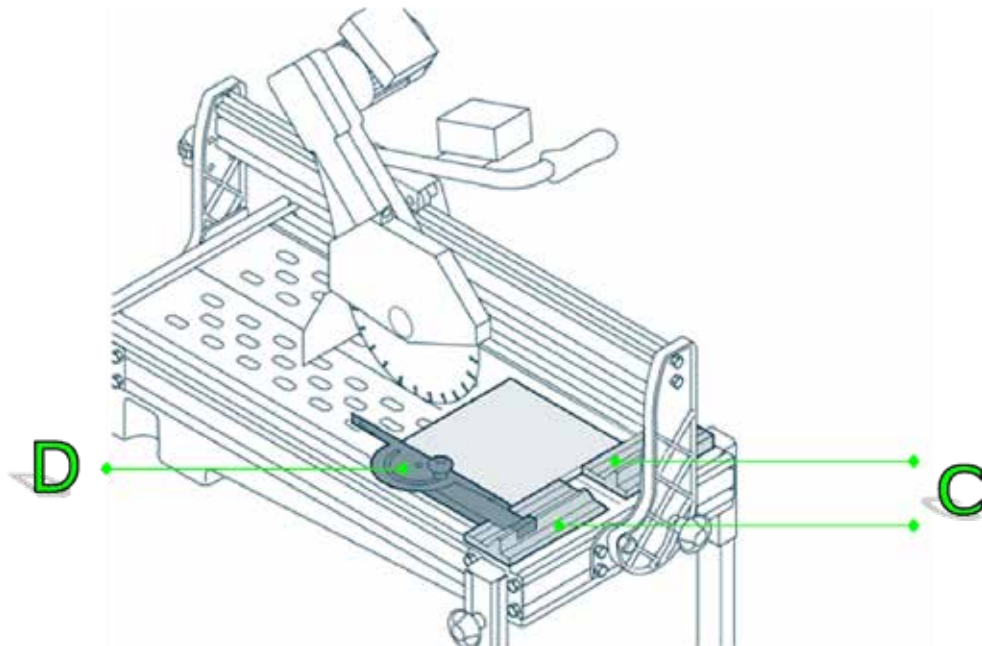

4. Adjust cut width following the job's needs (See: "Setting the Cutting Width").
5. Place the tile on the working table against the **(C)** guide.
6. Place the **(D)** goniometer against the tile.

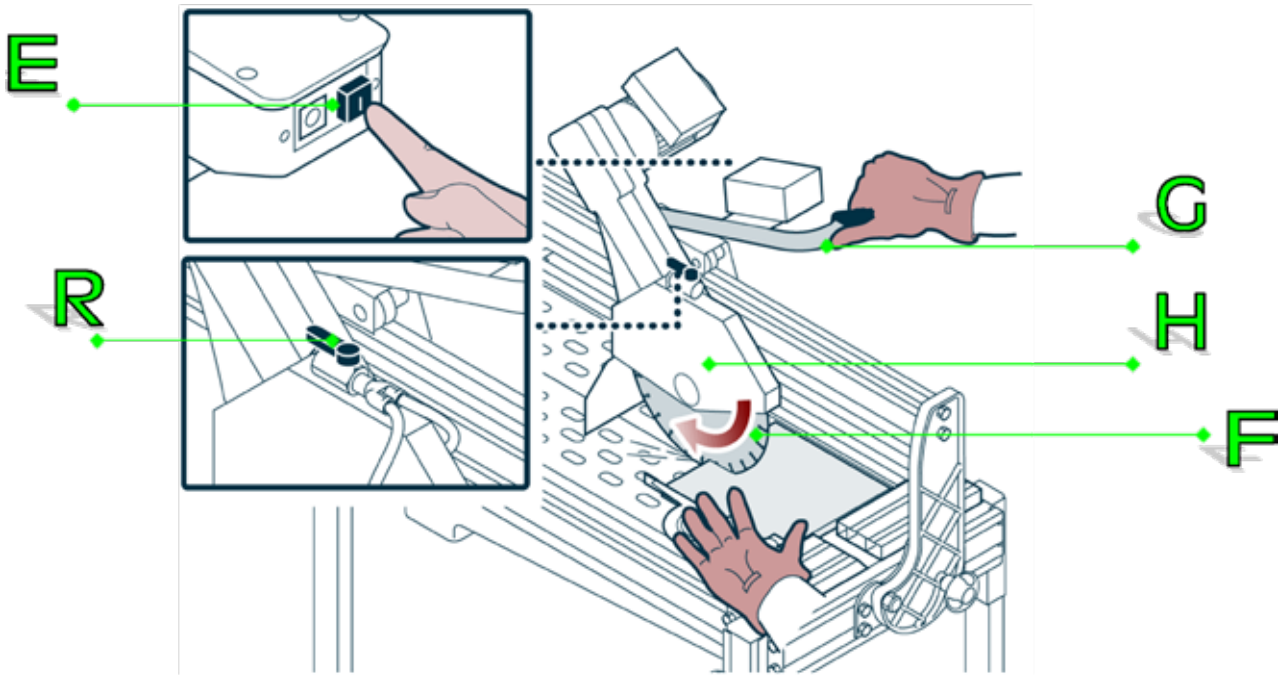

7. Apply hand pressure on the tile and block it on the top.
8. Turn the **(E)** switch on (pos. I) to activate **(F)** cutting blade rotation.
9. Adjust the **(R)** tap to optimize water's flow.
10. Grasp the **(G)** handle and slowly bring the cutting group forward **(H)**.
11. Proceed with the cut.

6.5.2 – Diagonal cut



1. Loosen the **(A)** knob.
2. Loosen the **(B)** knob and bring the cutting group in its full-lowered position.
3. Re-tighten the **(B)** knob.

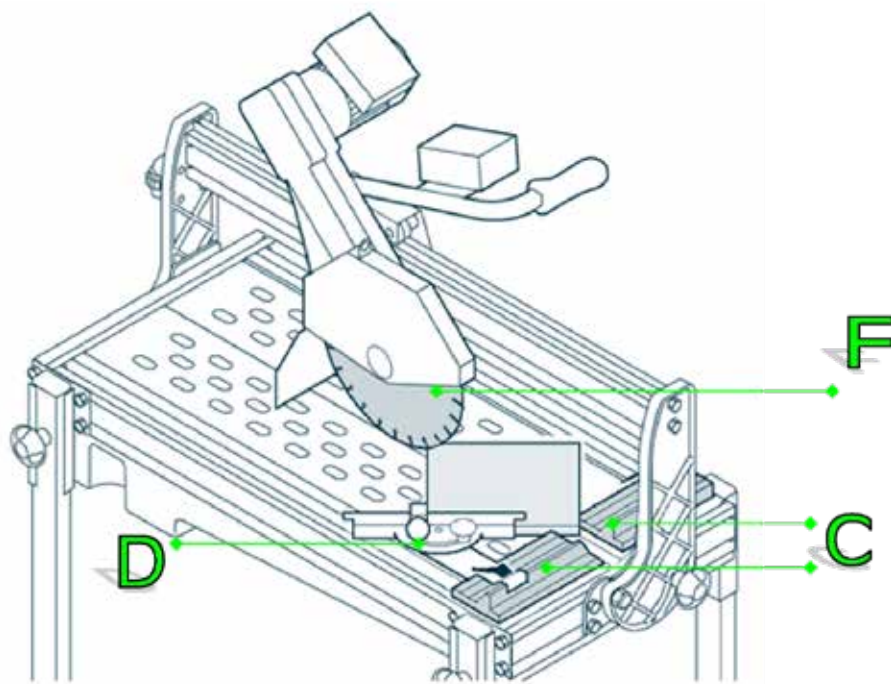

4. Adjust cut width following the job's needs (See: "Setting the Cutting Width").
5. Place the tile on the working table, against the **(C)** guide.
6. Place the **(D)** goniometer against the tile.

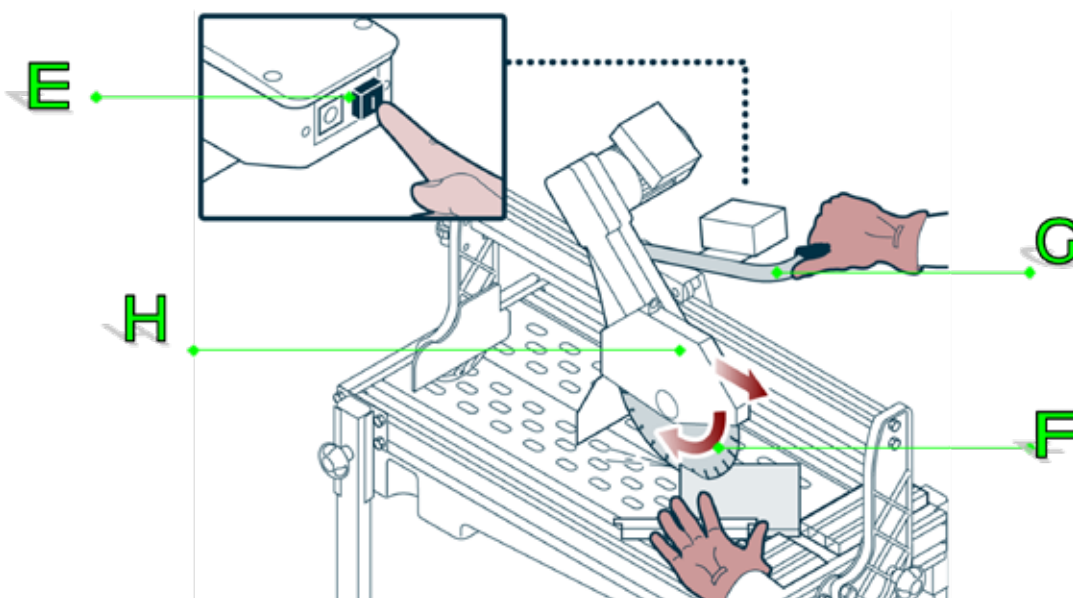

7. Apply hand pressure on the tile and block it on the top.
8. Press the **(E)** switch (pos. I) to activate cutting blade rotation **(F)**.
9. Adjust the **(R)** tap to optimize water's flow.
10. Grasp the **(G)** handle and slowly bring the cutting group forward **(H)**.
11. Proceed with the cut.

6.5.3 – Setting for 45 Degree Cut



1. Remove the **(A)** knob
2. Loosen the **(B)** knob and bring the cutting group down until the blade's lower rim plunges just below the table surface. Re-tighten the **(B)** knob.
3. Loosen both symmetrical lock knobs **(C)** and tilt the upper part of the machine (bridge + cut head) **(D)** on its side. Re-tighten the **(C)** knobs.

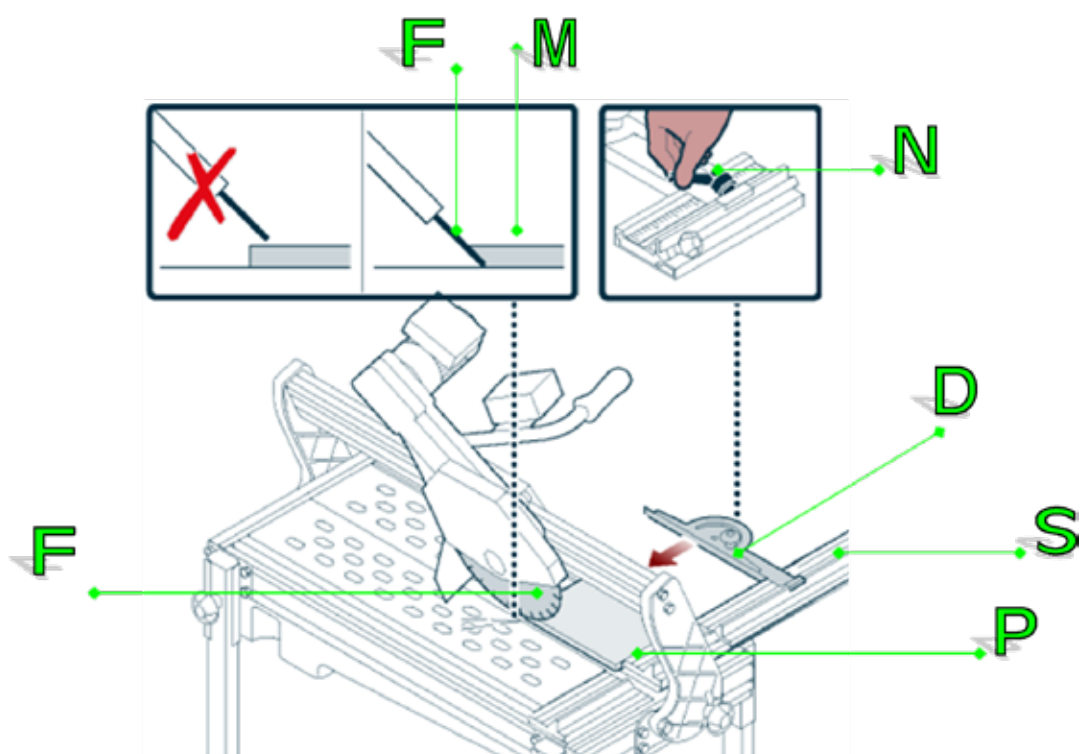

4. Insert the **(S)** extension into the **(P)** guide if needed (see "Accessories Installation").
5. Put the tile on the work table, making sure that the **(F)** blade could not damage the tile's glazed surface **(M)**.
6. Loosen the **(N)** knob, adjust the **(D)** goniometer on the tile, and re-tighten the knob.

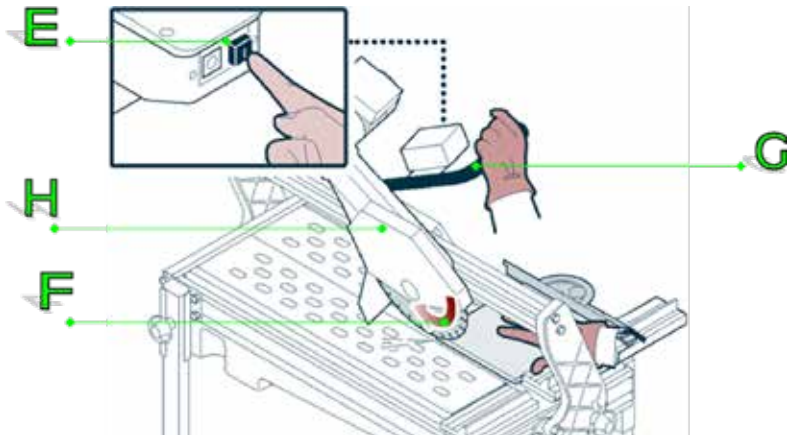

7. Apply right hand pressure on the tile and block it on the top.
8. Turn the **(E)** main switch onto (pos. I) and blade's rotation will start **(F)**.
9. Adjust the tap to optimize water's flow.
10. Grasp the **(G)** handle and, slowly, bring the cutting group forward **(H)**.
11. Proceed with the cut.

6.5.4 – Hole cut

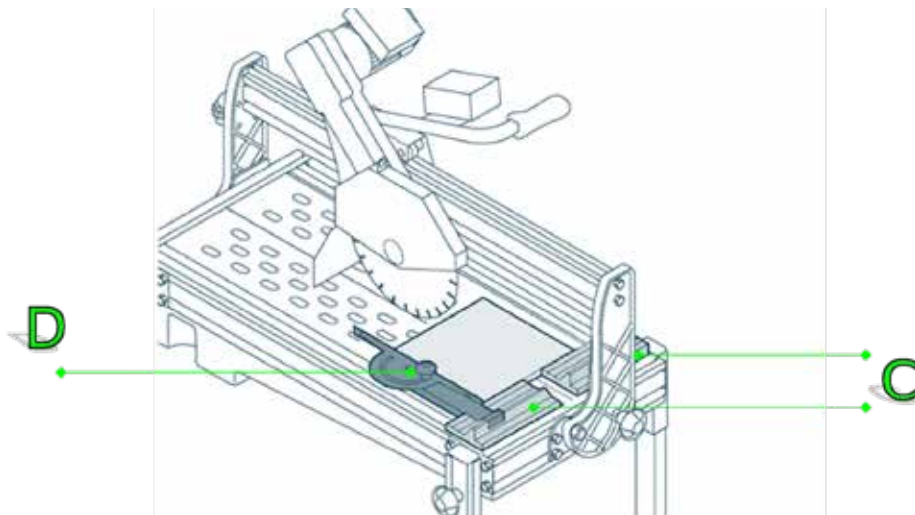

1. Put the tile on the work table positioning it against the base guide **(C)** and on the goniometer **(D)**. (See: Setting the Cutting Width)



2. Loosen the **(A)** knob move the cutting group in its desired position, then retighten the **(A)** knob.
3. Loosen the **(B)** knob to allow for vertical cutting group movement.

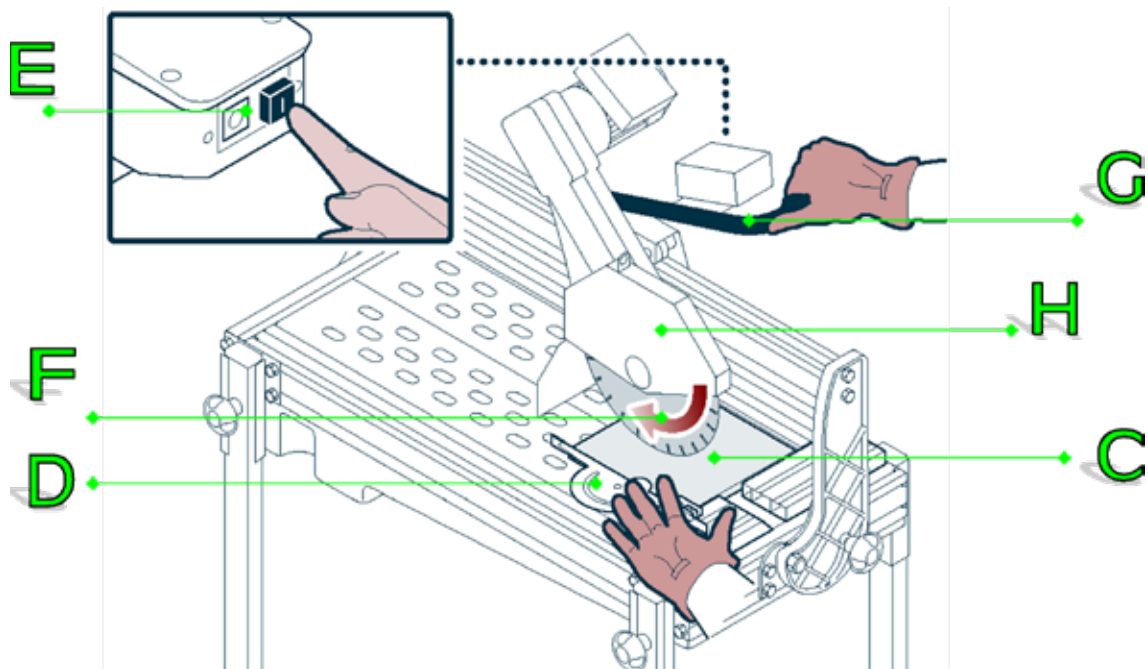

4. Lay the **(C)** tile onto the work table resting it against the base reference guide.
5. Make sure that the cut group **(G)** is in full high position.
6. Turn the **(E)** main switch onto (pos. I) and blade's rotation will start **(F)**.
7. Adjust the tap to optimize water's flow.
8. Apply left hand pressure on the tile to block it on the table top.
9. Cut by plunging the cut's head **(G)** down.
10. Rotate the tile and repeat 3 times to finish a rectangular hole.

6.6 – Long inactivity

In case the machine remains inactive for a long time, please proceed as follow:

- Perform all maintenance operations.
- Perform a general cleansing.
- Watch over the electrical contacts using an antioxidant spray.
- Put the machine in a sheltered place, accessible only by authorized personnel.

7 – MAINTENANCE INFORMATION

7.1 – Maintenance recommendations



IMPORTANT

Before doing any work or taking any action on the machine, turn main power OFF.

Always keep the machine in maximum efficiency conditions, and perform maintenance as suggested by the manufacturer on regular schedules. A good maintenance program ensures optimum performance, longer service life and keeps safety requirements always in effects.

Whomever authorized to perform such operations must take into account all the necessary precautions to ensure the safety of all people involved, in accordance with work safety law compliance requirements.

7.2 – Maintenance Schedule Table

Frequency	Component	Action Type	Action
Work Start	Cutting blade	Integrity check	Check wear and replace if needed
	Switch		Check release coil operation. Turn machine ON, unplug supply cable without turning machine OFF. Re-plug supply cable IN. The engine should not start, the blade should not start spinning.
	Protections		Check protections' wear and operation, and cut visibility. Replace if needed.
Work end	Tank	Cleansing	Completely empty the water tank and cleanse it.
Monthly	Transmission belt (where applicable)	Tension check	Check tension. Adjust if needed.
		Wear check	Check teeth wear or possible break-ups. Replace if needed.
	Water pump	Filter cleansing	Clean filter with air or water jet

7.3 – Sliding Wheels' Adjustment

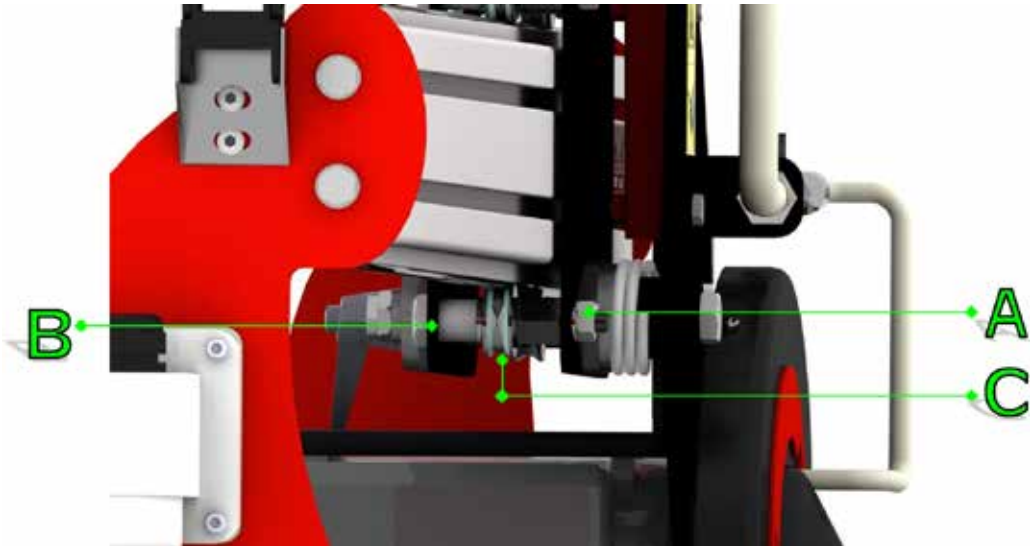

Please proceed as follows:

1. Loosen both **(A)** nuts locking the two wheels installed under the cut group.
2. Turn both eccentric **(B)** hexagonal screw until both **(C)** wheels are perfectly pressed against the rail.
3. Re-tighten the nuts **(A)**.

7.4 – Blade Parallelism Adjustment

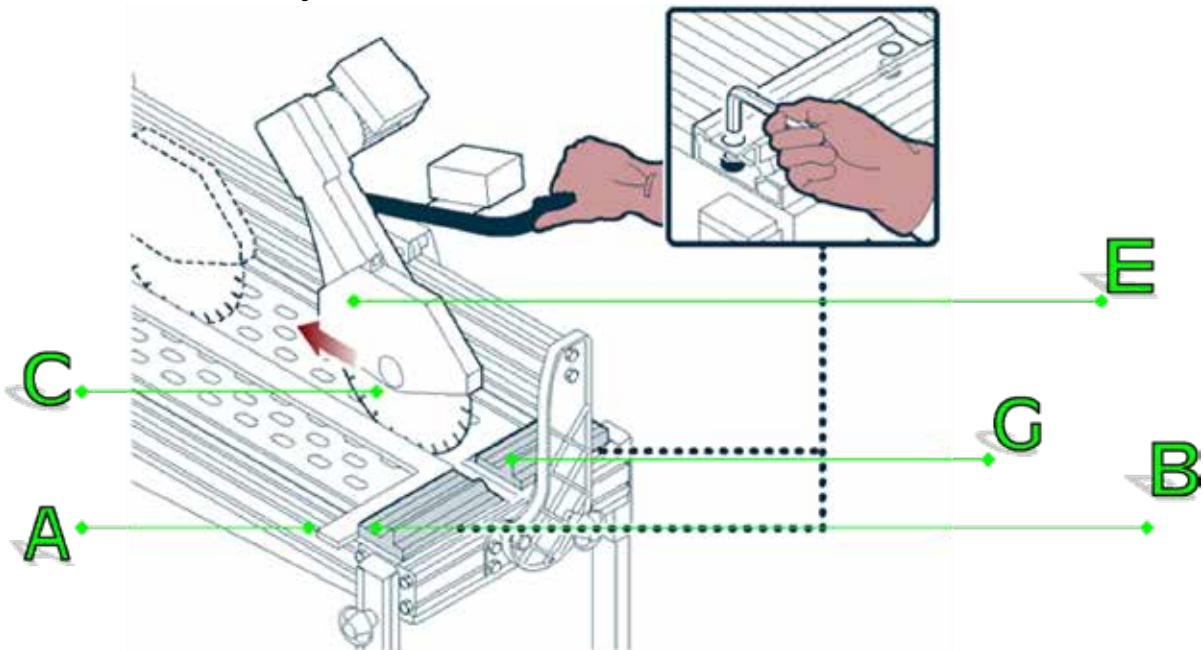

For this Operation please proceed as follows:

1. Lean a square **(A)** on the guide **(B)** and against the cutting blade **(C)**.
2. Grasp the handle and move the cutting unit **(E)** checking that the cutting blade **(C)** always remains parallel to the square **(A)**.
3. If necessary, loosen the screws **(F)** and set the guide **(B)** in order to keep the cutting blade **(C)** always parallel to the square **(A)**.
4. Repeat the same operation on the opposite guide **(G)**.

7.5 – Blade perpendicularity adjustment

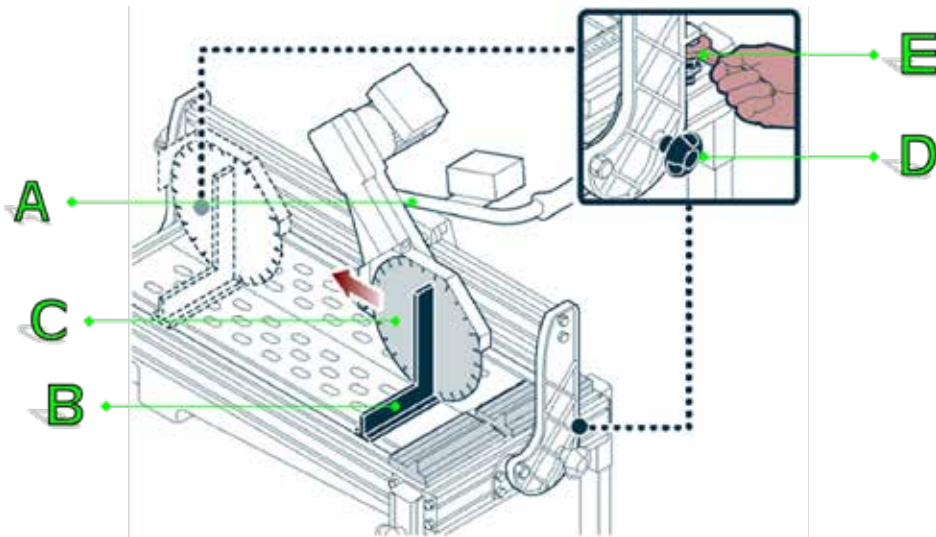

For this Operation please proceed as follows:

1. Remove blade protection as explained at point 4.7.
2. Place a square (B) on the working table and against the cutting blade (C) in order to check blade perpendicularity.
3. If necessary, loosen the knob (D) on both sides, then regulate the screw (E) until the cutting blade (C) is parallel to the square (B).
4. Move the cutting group (A) to the opposite end of the working bridge and repeat the same operation.

7.6 – Pump Maintenance

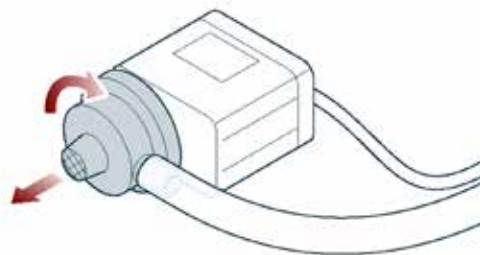

Turn the protection (A) 45° and pull it to remove it.

1. Clean the filter with compressed air or with a water jet.
2. Re-assemble the protection (A)

7.7 – Machine cleansing

Wash the machine with a cloth dampened with water

8 – TROUBLESHOOTING

8.1 – Problems, causes and remedies

The following information is intended to aid in identifying and correcting defects and malfunctions that may occur during use. Some of these problems can be solved by the user, all other required precise technical skills or special abilities and therefore may only be performed by qualified personnel with recognized expertise and experience in the specific field of intervention.

Inconvenient	Cause	Action
Machine does not start	Power supply circuit fault	Make sure power connector is firmly plugged IN
		Check electrical system efficiency
		Check switch breaker operation
Machine stops	Power supply circuit fault	Make sure power connector is firmly plugged IN
		Check electrical system efficiency
		Call customer service
Cut blade doesn't spin	Wrong installation	Check blade installation
	Damage to the electrical engine	Call customer service
Cooling water doesn't come out	Closed water pump's tap	Open the tap
	Clogged water pipe	Check the pipe's status
	Malfunctioning water pump	Clean the filter
		Replace the pump
	Insufficient water level	Check that the pump is fully submerged by water

9- ATTACHING THE TIRE WHEEL

Integrated Rubber Wheels - Easily Move Rail Saw From Jobsite To Jobsite

For this operation please proceed as follows:

1. Align the hole on the Tire Wheel bracket with hole on the Support Foot.
2. Insert knob and tighten.
3. Repeat for the other Support Foot.



10 - WARRANTY

- This machine is guaranteed for a period of 12 months from the date of purchase.
- The warranty is limited to defects in material or workmanship. It will not be valid if the machine is disassembled, tampered with or repaired outside the factory or by un-authorized operators.
- The warranty document is represented by the purchase document (invoice, receipt, etc..) or by the nameplate of your machine.
- The machines needing repair must be returned to the manufacturer with delivery duty paid. Warranty can be applied only if the machine is accompanied by its warranty document.



16 Park Dr Ste 9, Franklin, NJ 07416 • 800-648-7229
www.alpha-tools.com

Copyright © 2024 Alpha Professional Tools. All rights reserved.

06/2024